

THIS IS ISSUED IN STRICT CONFIDENCE THAT IT IS NOT USED AS A BASIS FOR MANUFACTURE OR SALE AND THAT IT IS NOT COPIED, REPRINTED OR DISCLOSED TO A THIRD PARTY EITHER WHOLLY OR IN PART WITHOUT THE PRIOR WRITTEN CONSENT OF CAL TEST ELECTRONICS, INC.

NOTES:

1. MATERIAL:
 1. CENTER CONTACT: BERYLLIUM COPPER, GOLD OVER NICKEL
 2. BODY & COUPLING NUT: BRASS, NICKEL PLATED
 3. GASKET: SILICONE
 4. DIELECTRIC: PTFE
2. SPECIFICATIONS:
 1. IMPEDANCE: 50 OHMS
 2. FREQUENCY RANGE: DC TO 4 GHZ
 3. VSWR (MAX.): 1.30:1
 4. OPERATING TEMPERATURE: -20 °C TO +80 °C
3. ROHS 2 COMPLIANT; EXEMPTION ANNIX III 6(C).
4. PACKAGING:
 1. INDIVIDUAL: 1 PC PER BAG.
 2. WEIGHT: 39 G/PC

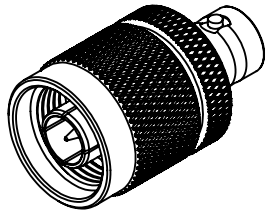

REVISIONS			
REV.	DESCRIPTION	DATE	APPROVED
-	CLASS A RELEASED	9/9/1996	
A	UPDATED NOTE 1, ADDED GASKET: SILICONE NOTATION	2/18/2015	
B	UPDATED TO METRIC FORMAT; ADDED NOTES 3 & 4	6/18/2018	
C	UPDATED TO NEW DRAWING FORMAT (SW)	2/14/2019	

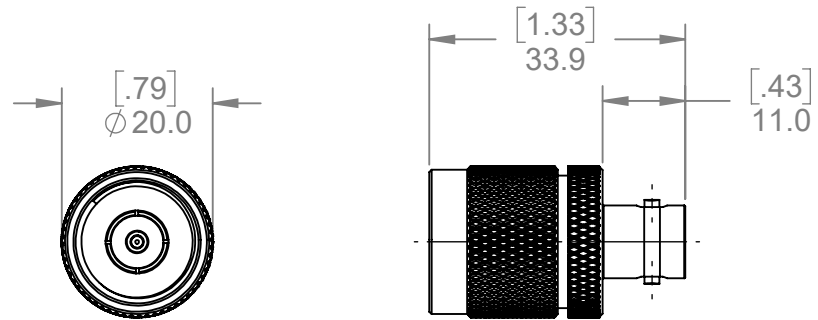

METRIC

THIRD ANGLE PROJECTION

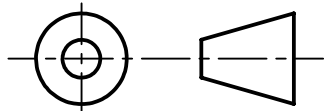

UNLESS OTHERWISE SPECIFIED DIMENSIONS ARE IN MILLIMETERS TOLERANCES ARE: PER DIN ISO 2768m

DO NOT SCALE DRAWING

MATERIAL SEE NOTES

TREATMENT NONA

FINISH SEE NOTES

PROJECT NO.

N/A

APPROVALS

DATE

DRAWN

WDH

2/14/2019

CHECKER

B.Hansen

2/14/2019

ENGR.

NONE

DESIGN ACTIVITY

NONE

CT2762	BASIC PART	-
MODEL NUMBER	CONFIGURATION	NOTES / REFERENCE
MODEL NUMBER TABLE		

Cal Test Electronics

22820 Savi Ranch Parkway
Yorba Linda, CA 92887

TITLE

ADAPTER, N (m) to BNC (f)

SIZE

A

CAGE CODE

43F45

DWG. NO.

P276200

REV.

C

SCALE

1:1

SHEET

1 OF 1