

THIS IS ISSUED IN STRICT CONFIDENCE THAT IT IS NOT USED AS A BASIS FOR MANUFACTURE OR SALE AND THAT IT IS NOT COPIED, REPRINTED OR DISCLOSED TO A THIRD PARTY EITHER WHOLLY OR IN PART WITHOUT THE PRIOR WRITTEN CONSENT OF CAL TEST ELECTRONICS, INC.

REVISIONS			
REV.	DESCRIPTIONS	DATE	APPROVED
-	CLASS A RELEASED	7/12/04	

1. TEST PROBE LEAD w/4mm SPRING CONTACT TIP, 0.75mm², SILICONE JACKETED WIRE.

2. SPECIFICATIONS:
WIRE:

DOUBLE INSULATED SILICONE (-60° C TO +180° C)
195x0.07mm STRANDED BARE COPPER, 0.75mm² CROSS SECTION (18AWG), Ø.146±.008 (Ø3.7±0.2mm) O.D.

INSULATED HOUSINGS:

PA6 (NYLON) THERMOPLASTIC.
UL94V-0.

CONTACTS:

PLUG BODY & TIP: BRASS, NICKEL PLATED
CONTACTS: 4mm, 9 LEAF-BECU, NICKEL PLATED.
INSULATED TIP ON PLUG BODY, GREY

3. RATING:

1,000V CATIII P2 PER IEC61010-031
CURRENT: 12A MAX.
TEMPERATURE: -20° C TO +80° C.

CE DECLARATION OF CONFORMITY:

VOLTAGE: 1000V CATIII P2, IEC61010-031 (HANDHELD)
CURRENT: 12A MAX.

PART NUMBER

CT2309-L-#



COLOR: **0** - BLACK
2 - RED

LENGTH: (CENTIMETERS)
STANDARDS: **100, 150**

THIRD ANGLE PROJECTION		UNLESS OTHERWISE SPECIFIED DIMENSIONS ARE IN INCHES TOLERANCES ARE: FRACTIONS DECIMALS ± 1/32 .XX ± .02 .XXX ± .005 DO NOT SCALE DRAWING	CONTRACT NO.		Cal Test Electronics 22820 Savi Ranch Parkway Yorba Linda, CA 92887-4610			
			APPROVALS	DATE	TITLE			
NEXT ASSY		MATERIAL	DRAWN	7/12/04	TEST PROBE LEAD w/4mm CONTACT TIP, 0.75mm ² , SILICONE WIRE			
USED ON		FINISH	CHECKED		SIZE	CAGE CODE	DWG. NO.	REV.
APPLICATION			ENGR.		A	43F45	P230900	-
			DESIGN ACTIVITY		SCALE	NONE	SHEET	1 OF 2

THIS IS ISSUED IN STRICT CONFIDENCE THAT IT IS NOT USED AS A BASIS FOR MANUFACTURE OR SALE AND THAT IT IS NOT COPIED, REPRINTED OR DISCLOSED TO A THIRD PARTY EITHER WHOLLY OR IN PART WITHOUT THE PRIOR WRITTEN CONSENT OF CAL TEST ELECTRONICS, INC.

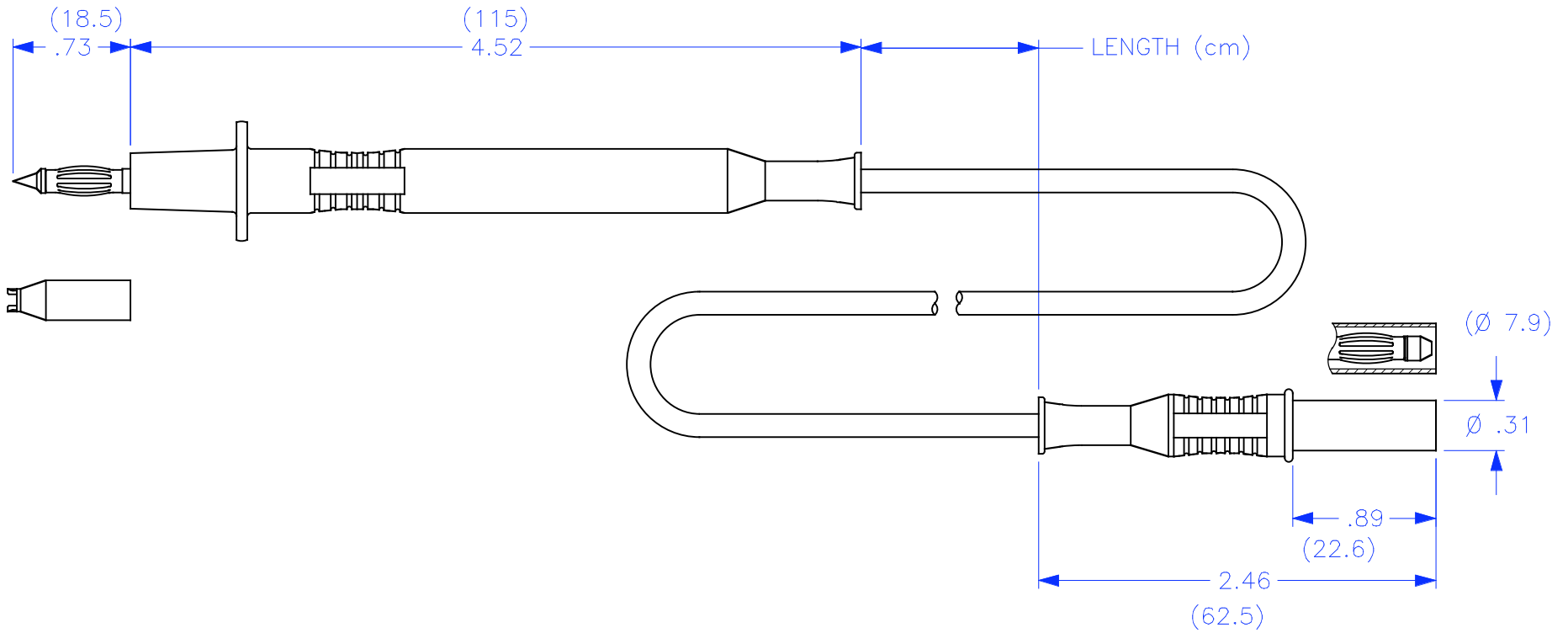

DRAWN	WDH	7/12/04	SIZE	A	CAGE CODE	43F45	DWG. NO.	P230900	REV.	-
CHECKED			SCALE	1:1			SHEET	2		