

DC Electronic Load

Application Note

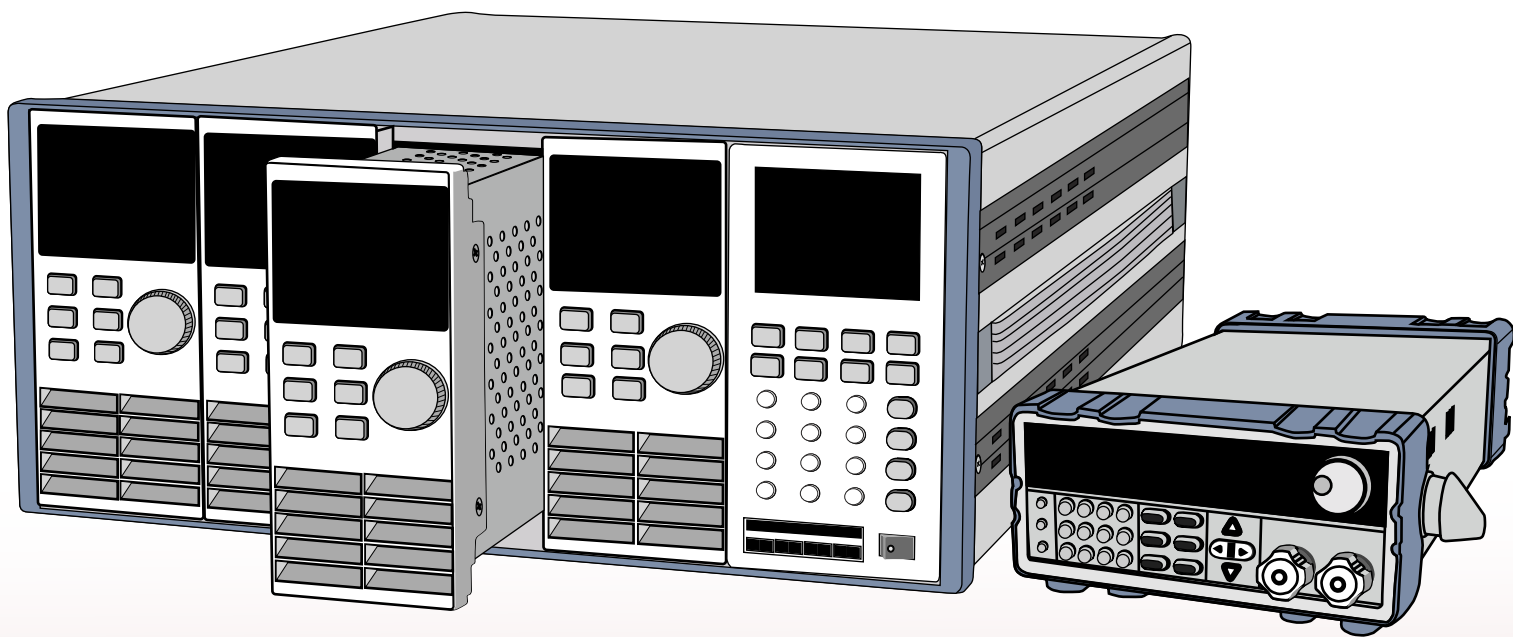



DC Electronic Load Applications and Examples

Application Note

V 3032009

Table of Contents

INTRODUCTION	3
<i>Overview of software examples</i>	3
POWER SUPPLY TESTING	4
<i>Load Transient Response</i>	4
<i>Load Regulation</i>	5
<i>Current Limiting</i>	6
BATTERY TESTING	7
<i>Battery Discharge Curves</i>	7
<i>Battery Internal Resistances</i>	8
PERFORMANCE TESTING OF DC LOADS	10
<i>Slew Rate</i>	10
OTHER DC LOAD APPLICATIONS	11
<i>Voltmeter</i>	12
<i>Fuse</i>	12
SOFTWARE EXAMPLES	12
<i>Battery Discharge Test</i>	13
<i>Voltmeter Reading</i>	15
<i>Fuse Application</i>	15
Reference	16

INTRODUCTION

As technology is constantly advancing, demands for quality test instruments increase due to the need for making better and accurate measurements to accommodate newer technologies. For most electronic applications today, using energy efficient and reliable power sources is critical. For this reason, it is important to have a test instrument that can accurately portray results that define the performance of the power sources used to provide electricity for devices such as electrical vehicles, computer power supplies, 3G cellular phones, and even consumer standard household batteries. Programmable DC Electronic loads are one such instrument that will aid in testing various settings, configurations, schemes, and methodologies. The intention of this application note is to provide a general scope of a DC load's usage. Some standard performance tests for testing power supplies will be described in details. Furthermore, several methods for testing the DC load itself will be included in the later sections. Additional details on practical DC load applications and setup information are provided as a source to assist in performing various test setups and measuring data. As a note, all software examples contained in the

later sections utilize B&K Precision's DC load model 8500 as part of the different setups and test configurations. Most applications can be simulated in the same fashion with other brands of DC loads, with the exception of all the software examples. They are written specifically for full compatibility with B&K Precision's 8500 series DC loads and are not intended to support other brands of DC loads. In general, any measurements made with B&K Precision's equipments are typical, but not guaranteed.

Overview of software examples

Throughout some of the sections in this application note, software examples are provided to enhance and simplify test methods as well as to bolster features of B&K Precision's 8500 series DC loads that can be controlled remotely with a PC computer via RS-232 interface. Unless otherwise noted, all examples are written in python programming language. They also require two python libraries and the 8500 DC load COM library installed on the PC used for communication in order to operate correctly. To obtain all these as well as instructional documentation for installation and setup, please visit one of our DC load product pages at: <http://www.bkprecision.com/products/dc-electronic-loads/8500-300-w-programmable-dc-electronic-load.html>.

Unfortunately, the software files are supported only for Windows platforms. However, due to the excellent cross-platform capabilities of python, some users may be able to get the library (which does not have to be utilized via COM) working on other platforms. Please see the library's documentation for more details.

Although the software and examples are written in python, users who have other particular preferences in terms of the programming language to use can easily use the COM library provided in the software package to write similar examples in the language of their choice. Some languages that have been found to work well with the COM library are Visual Basic and Visual C#. Other languages are also expected to work with the library, given the correct declarations and modifications within the program.

POWER SUPPLY TESTING

For design testing and verification, the need for regulated power supplies are increasing with ongoing advancement in technology. More so, it has become a necessity in newer electronic devices to be tested with precise and sophisticated power supplies. There are some specifications that determine some underlying performance factors in typical power supplies. Particularly, the load transient response, load regulation, and current limit. In the following sections, each of these factors are addressed as an example to describe and demonstrate the setup, configuration, and equipment required for testing and verification. Each example will utilize a DC load as part of the setup.

Disclaimer: The following sections include general setups with some settings specified for the test environment. Some details are ignored, and therefore

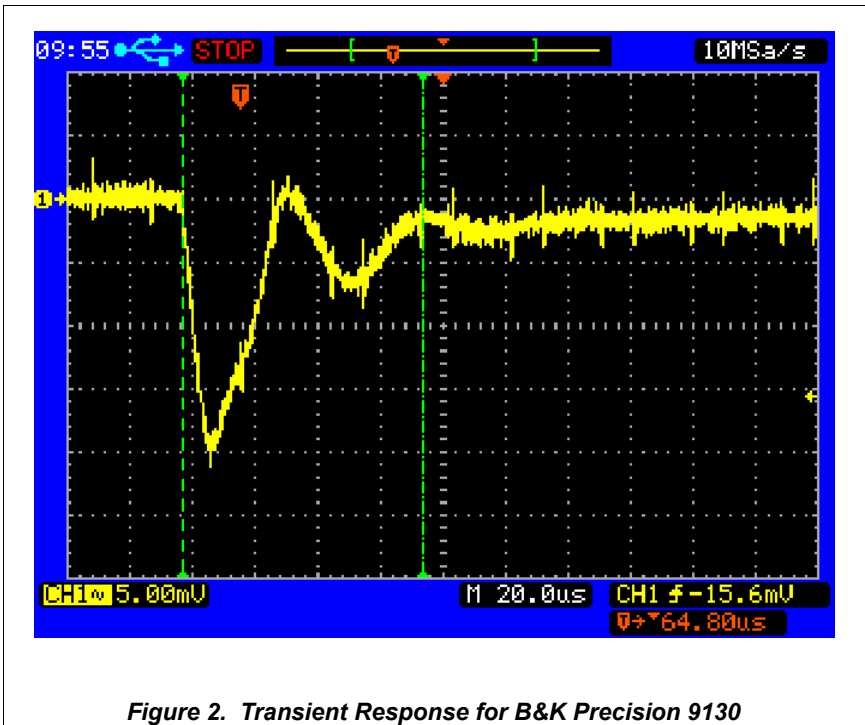

Figure 2. Transient Response for B&K Precision 9130

results may vary and may not reflect exactly what is shown in the following sections.

Load Transient Response

An important element to power supply testing is a measurable unit of load transient response, which characterizes the capability of the power supply to stabilize itself upon a step change in

the load current. In order to verify the response, measurements of the rise and fall times upon a step change in the load is necessary. Generally, this type of test requires a load that is able to produce a rise and fall time approximately five times faster than the power supply. The following application demonstrates an effective approach to testing the load transient response of a power supply.

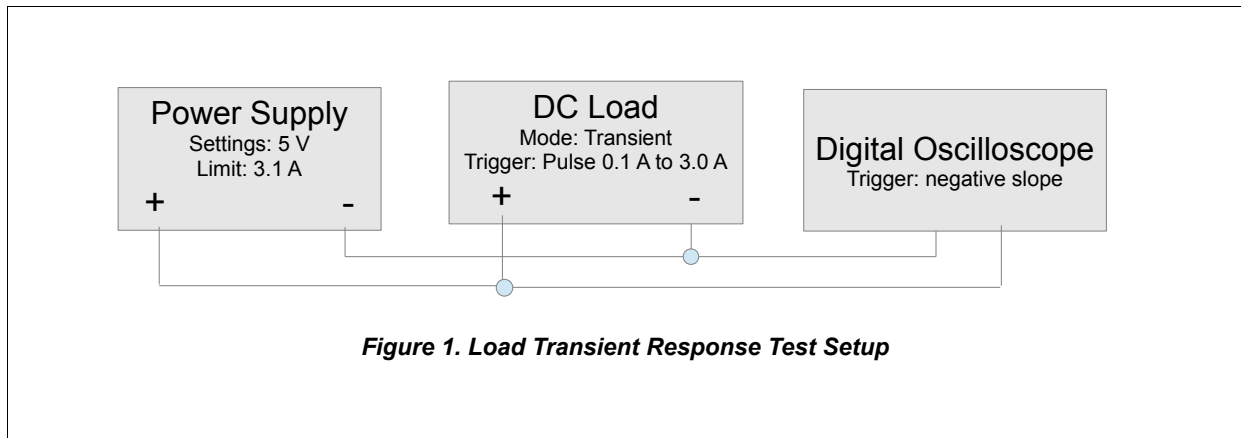

Figure 1. Load Transient Response Test Setup

Objective

Characterize the time it takes for a power supply to stabilize its output voltage after a step change in the load.

Approach

Connect a DC load to a power supply. Use the DC load's transient mode to apply a step change in load to the power supply.

Setup

A power supply was set to 5 V output with the current limit set to 3 A. A digital oscilloscope was used to view the power supply's output voltage. The scope was AC coupled and set to trigger on a negative slope.

DC Load Setup

The DC load was set to transient mode from 1.5 A to 3 A. Pulse triggering mode was selected for the DC load, which means a trigger signal causes the load to go from 1.5 A to 3 A, then back to 1.5 A.

Results

Looking at Figure 2, the load transient response is observed during the rise time in the load

with a step change from 1.5 A to 3 A. The output voltage dropped by approximately 1.6 mV.

Load Regulation

Load regulation is another important element when testing a power supply. It is a performance measurement that requires setting the power supply to its rated voltage. To be specific, the test for measuring this element is based on measuring the output voltage levels of the supply when a load connected to it changes from zero current to rated current, which differs depending on the model used under testing. The purpose for this test is to ensure the accuracy and capability for a power supply to maintain its voltage output level under rated load current changes. Before testing, verify that the load used for the test supports the maximum rated current and voltage of the power supply.

Objective

Measure the change in output voltage from no current load to the rated current load of the power supply.

Approach

Use a DC voltmeter to measure the voltage change when the DC load is used to step the power supply from 0 current to rated current.

Setup

The measurement is conceptually simple, but it is **critical** that the voltmeter used to measure the voltage change is connected to the output terminals of the power supply independently of the leads used to connect to the DC load. Failure to do this will measure the contact resistance of the power leads, overestimating the load regulation and output resistance of the power supply. Connect the voltmeter and DC load in parallel to the power supply's terminals (See Figure 3 for setup diagram).

DC Load Setup

Press the I-set button (for B&K Precision DC loads) to change the DC load to constant current mode (you may have to press the button twice). Set the current to the rated current of the power supply.

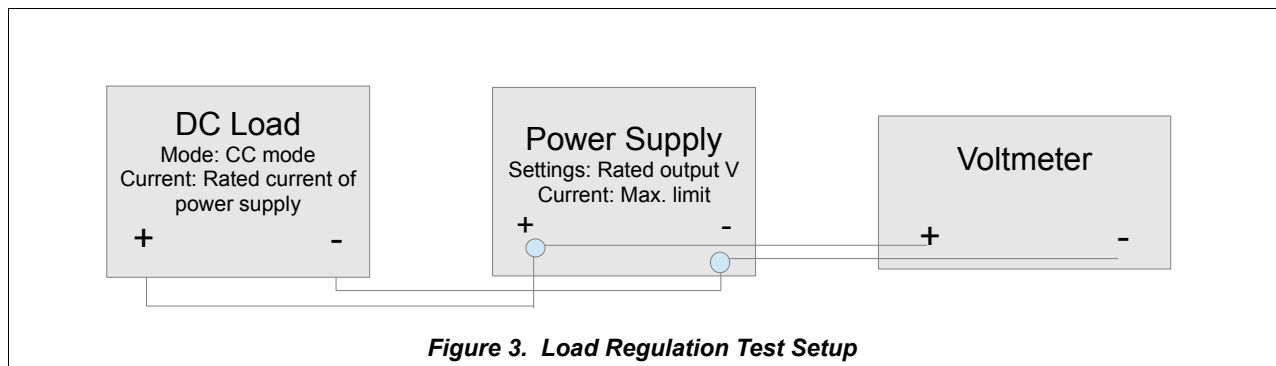

Figure 3. Load Regulation Test Setup

Procedure

1. Turn on the power supply and set it to its rated output voltage. Ensure that the current adjust knob, if present, is set to its maximum value.
2. Write down the measured voltage of the power supply. Call this value V_0 .
3. Press I-set on the DC load to set to power supply's rated value. Turn on the input of the load by pressing On/Off.
4. Write down the measured voltage of the power supply. Call this value V .
5. Turn off the DC load's input by pressing the On-Off button.
6. Turn off the power supply.

Calculate the load regulation (in percent) of the power supply by

$$100 \frac{V_0 - V}{V_0} \quad (1)$$

You can also calculate the output resistance of the power supply as $\frac{(V_0 - V)}{i}$ where i is the current drawn in this test.

High quality power supplies have low output resistances in the order of 1 m Ω or less. This means measuring V_0 and V with enough digits is necessary to avoid loss of significance in the subtraction. As an example, for a 30 V supply rated at 3 A with an output resistance of 1 m Ω ,

measuring 30 V with 100 μ V resolution is required to have two significant figures in the load regulation number. This measurement would require a 6 digit voltmeter.

Current Limiting

Power supplies in constant voltage mode generally have a preset limit to the maximum current output. Current limit testing consists of measurements that define the behavior of a power supply and its current regulation. These measurements can be characterized by a voltage vs. current curve, which portrays how and when the power supply enters from CV to CC mode. Ideally, precise current regulation reflects a voltage vs. current curve similar to Figure 4.

For CV/CC mode power supplies, typical current limit

characteristics look like Figure 4, with small or very minimal bending near the crossover point. It is good practice to test the current limits of a power supply because it will aid in protecting the equipment for its application. Without a certain degree of current regulation, the supply may even over power or damage certain devices. The following describes a test setup for testing current limit of a power supply.

Objective

Determine the current limit of a power supply under test.

Approach

Use a power supply, DC load, and a computer to analyze voltage versus current characteristics.

Setup

Connect the power supply in

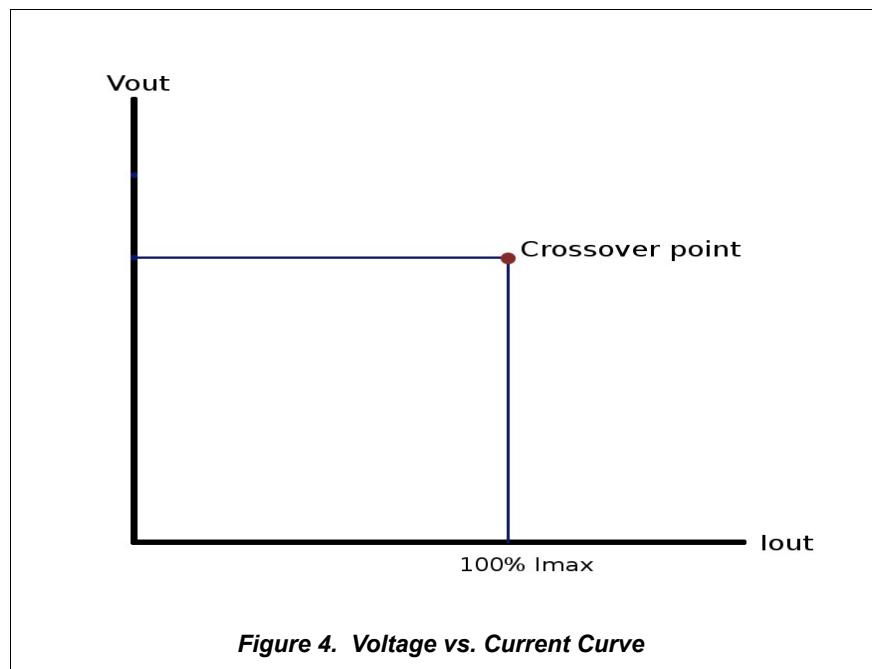

Figure 4. Voltage vs. Current Curve

parallel to the DC load. Set the power supply to its rated voltage and set a preset value for current. The DC load should display the rated voltage if power supply's output is on. Incrementally increase the current drawn from the load and observe the behavior of the voltage in the power supply. When the current on the load gets close to the power supply preset current limit, observe before, during, and after the crossover point, where the power supply switches from CV to CC mode.

DC Load Setup

Set the DC load to CC mode by pressing I-set (for B&K Precision DC loads). You may have to press twice. Turn on DC load's input.

Results

A DC power supply rated at 32 V and 3 A was tested with a DC load. The voltage from before to after the current crossover point was observed. Table 1 shows the data of some measurements to demonstrate the power supply behavior before and after the crossover point.

Power supply measurements (readings from power supply)		
Voltage	Current	Mode
32.0001 V	0.00024 A	CV
31.9999 V	2.65178 A	CV
31.9999 V	2.99467 A	CV
0.1569 V	2.99999 A	CC

Table 1: Measured Data from B&K Precision 9120A.

It follows that the measurements demonstrate a voltage vs. current curve similar to Figure 4. Drawing from the data, the voltage drops immediately upon reaching the crossover point, which is at 2.99467 A in this case. The power supply changes to CC mode after this point, and voltage remains at 0.1569 V, with current limited to 2.99999 A. This behavior is normal and expected for a CV/CC power supply. There are other types of power supplies with different current limit designs such as foldback current and CV power supplies (without CC mode). The voltage versus current curve will greatly differ from that of CV/CC power supplies, so it is advised to test their current limit characteristics before utilizing them in devices or applications.

BATTERY TESTING

The forms and standards for storing, renewing, and using energy are evolving. New methods for providing power for electronic products have been discovered and are far more complex than they were several decades ago. With increasing need in our society for clean and efficient energy, engineers have now turned their focus to develop applications that utilize, for example, fuel cells, supercapacitors, and photovoltaic energy. Due to the complexity in the design of

these sources, it is useful to have a programmable test instrument that can verify precise details of the sources' behavior. This is often where a DC load comes in handy because of its programmable flexibility as well as its capability to run discharge tests on power sources like batteries. This section will provide a basic overview that demonstrates an efficient way to perform battery discharge and internal resistance testing.

Battery Discharge Curves

When designing and testing a battery for powering a device, a great deal of attention reflects on energy efficiency and lifetime. For this reason, a standard performance test consists of analyzing discharge curves that characterize the behavior of the battery. By observing these curves, the battery life can be measured, and its efficiency can be computed. Some DC loads provide this feature to allow battery discharge measurement, in which the total charge is provided in Ah (ampere*hour) to a specified voltage. B&K Precision's 8500 and 8600 DC load Series provide this useful built-in function for quick setup and testing. Battery discharge can also be tested with the provided program under the "Software Examples" section of this note. Additionally, small changes to the program will offer even greater control for the test, allowing measurements to be made under different modes and settings. The following

describes the discharge test setup for a consumer "AA" size battery. Similar setups can also be used for other types of batteries.

Setup

Connect the battery to the DC load. You can either solder wires to the battery or use a battery holder.

DC Load Setup

The setup is controlled by the program, but be sure to manually set the voltage and current range prior to running the test program. If the current is reasonably large, you might also want to suggest they use the remote voltage sensing feature of the DC load.

Results

Provided as an example is a plot (see Figure 6) of the battery discharge curve for the AA Alkaline battery tested with the setup in Figure 5. The command line used to run the program for the data is shown in Figure 7. The settings of the command are indicated in order as set to com port 5 in constant current mode with 0.5 A and a cut off voltage of 0.5 V. The file name for the data file is aa_test and "78deg F" is a string included at the end of each line of the file.

Note: For more details on the program commands and to run the test, find the instructions and use the python script provided towards the end of this application note categorized under "Battery Discharge

Test".

Battery Internal Resistances

The DC load is an effective tool for measuring the internal resistance of a battery. The battery is typically modeled as the dashed area in the circuit illustrated in Figure 8. The voltage source V_o is considered ideal and is the open circuit voltage of the battery. The internal resistance R_i is used to idealize the internal losses in the battery when current is flowing. If the battery's electrochemistry is regarded as a network of voltage sources and resistances, then V_o and R_i comprise the Thevenin equivalent circuit. For alkaline batteries, the internal resistance goes up as the battery's chemical energy is used up. The internal resistance drops as the

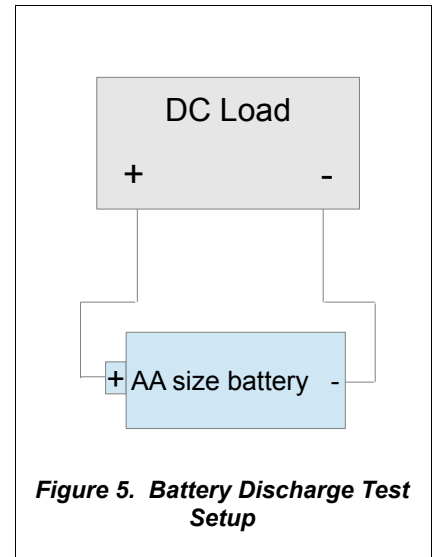

Figure 5. Battery Discharge Test Setup

temperature increases.

If V_L is the voltage across the load, we have

$$V_L = V_o + iR_i \quad (2)$$

Thus,

$$R_i = \frac{|V_L - V_o|}{i} \quad (3)$$

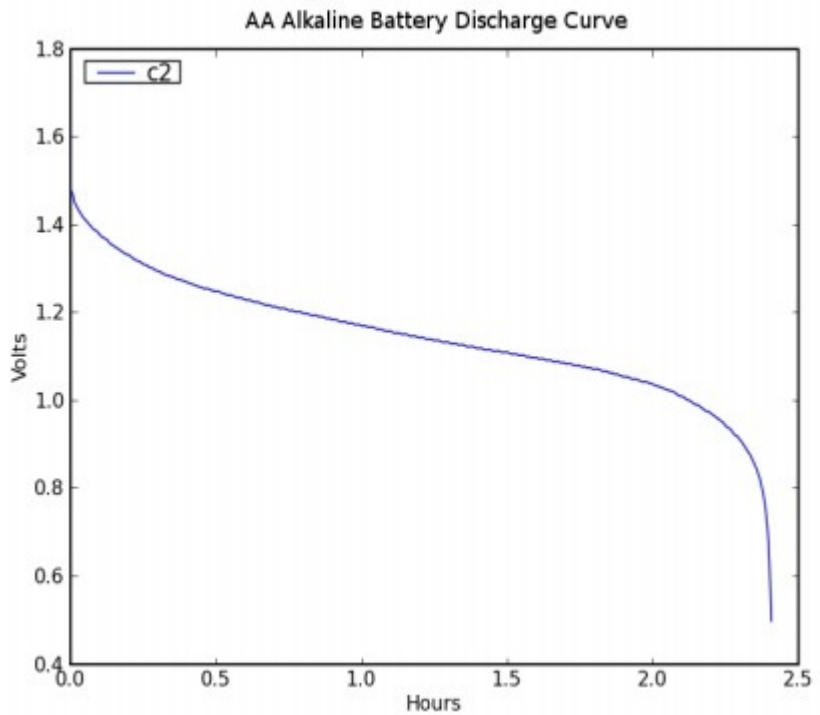

Figure 6. AA Alkaline Battery Discharge Curve

This gives us a way to evaluate the internal resistance using the DC load, either manually or by a program.

For smaller batteries, a programming approach is an advantage. Measurements can be made quickly, causing less drain on the battery. Using an oscilloscope, a millisecond-wide current pulse can be used to make a useful internal resistance measurement. The approach for measuring a "D" size battery's internal resistance is observed in the following. Note that this is only one of the practical ways for measuring internal resistance. There are other methods not mentioned here.

Approach

Measure the battery's voltage at two different current loads. The remote sense capability of the DC load will be used to avoid errors due to wire resistances. The test method follows the recommendation of [1] by applying a stabilization current of 5 mA, measuring the battery's voltage V_0 , applying a current of 505 mA, and measuring the voltage V . The internal resistance is measured as:

$$R_i = \frac{V_0 - V}{0.5} \quad (4)$$

Setup

Connect the battery to the DC load. Use a battery holder or solder wires to the battery if necessary. If soldering wires, do not overheat the battery due to risk of rupture.

```
python battery.py 5 cc 0.5 0.5 aa_test 78deg F
```

Figure 7. Command Used to Run Program

Connect two wires as close to the battery terminals as possible and run these to the remote sense terminals on the DC load (be sure to observe the proper polarity). Turn on load with the configurations under "DC Load Setup" below. Make sure the battery voltage has stabilized and write this down as the starting voltage V_0 . Then trigger the transient current levels and immediately watch the displayed voltage. Within two seconds, make note of the lowest voltage displayed and label this as V . Use equation (4) to calculate the internal resistance. A setup diagram is provided in Figure 9 for the purpose of illustration.

DC Load Setup

1. Turn on DC Load's remote sense feature.
2. Set trigger to immediate.

3. Set load to CC mode at 0.005 A.
4. Setup transient mode with current levels from 0 A for 0.5 ms to 0.505 A for 2000 ms in pulse mode.

Results

Using the test setup in Figure 9, the stabilization voltage (V_0) for the measured battery is 1.496 V. With 0.505 A load, the voltage (V) is 1.415 V. Using equation (4) gives an internal resistance of 0.16 Ω .

Batteries are complex nonlinear electrochemical devices. The two common electrical measurements of batteries used to gauge their state are the DC internal resistance and the AC internal impedance. In the "old" days, AC characteristics of a battery were not terribly important for

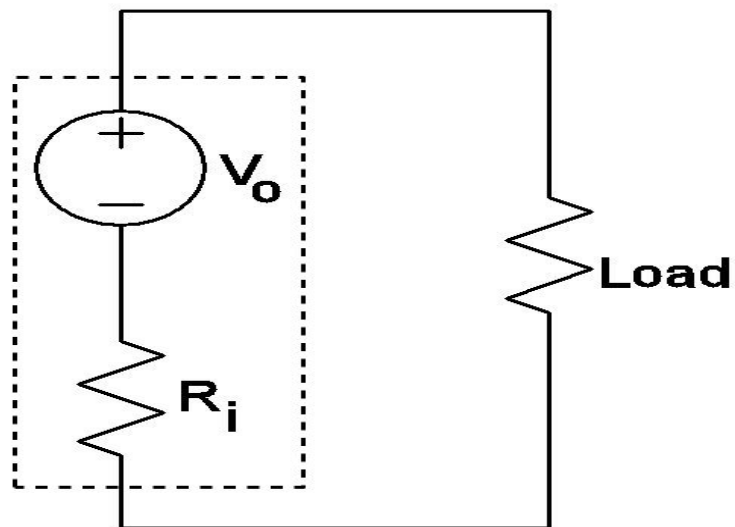

Figure 8. Circuit Model of Battery and Internal Resistance

DC operation. However, modern digital electronic devices can draw sharp current spikes from their power source (e.g., switching a cell phone to transmit). In a 1 kW car audio system, currents can exceed 100 A and the AC behavior of batteries, stiffening capacitors, and stray inductances can all play a role. DC loads can be useful in helping investigate the dynamic behavior of these systems.

The simple model of a battery as an ideal voltage source in series with a resistance captures the first order behavior (see Figure 8). More complex models have also been used. Using DC loads, batteries can be characterized in a manner which will mirror their application and construct a model appropriate for the design.

PERFORMANCE TESTING OF DC LOADS

Just as it is important to have a good power supply that will perform accurate measurements under various test conditions, it is essential to have a DC load that is robust and perform under required specifications and test setups. Some of the most common tests used for verifying features of a DC load include trigger delay, switching time, and slew rate.

Disclaimer: *The following sections include general setups with some settings specified for the test environment. Some details are ignored, and therefore results may vary and may not reflect exactly what is shown in the following sections.*

10% and 90% region, the slew rate can be measured by observing the steepest slope portion. The indicated measured time would be used to calculate the slew rate. Hence, the slew rate calculation is simply (rated max. current – 0 A) / T, where T is the measured time from 10% to 90% region and rated max. current is the specified maximum current of each load. The following will demonstrate how to test the slew rate of a DC Load.

Approach

Set the DC load to transient mode and allow it to draw current from 0 to maximum rated current. Observe current transition changes and timing on an oscilloscope.

Setup

Three 50 A high current power supplies are connected in parallel. This can produce enough current for a 120 A-rated load to draw at its maximum range. A handful of shunt resistors rated at 5 W 0.22 Ω are connected in parallel and are connected to a BNC-to-binding post adapter. A larger shunt can also be used to simplify the same setup and reduce the temperature from heat dissipation. Since high current will be drawn, it is important to note here that heavy gauge wires should be used to connect the power supplies to each other and to the load. Connect the power supply to the DC load and shunt resistors as illustrated in

Slew Rate

The slew rate of a DC load is a performance measurement that determines how quickly a DC load can draw current within different ranges of current transition. In general, the slew rate for low current transitions, say 0 to 0.5 A, is significantly lower than slew rate for current transitions from 30 to 70 A. Generally, the appropriate way to test slew rate is to observe a portion of the timing during maximum current transition. The graph in Figure 10 illustrates this. Between the

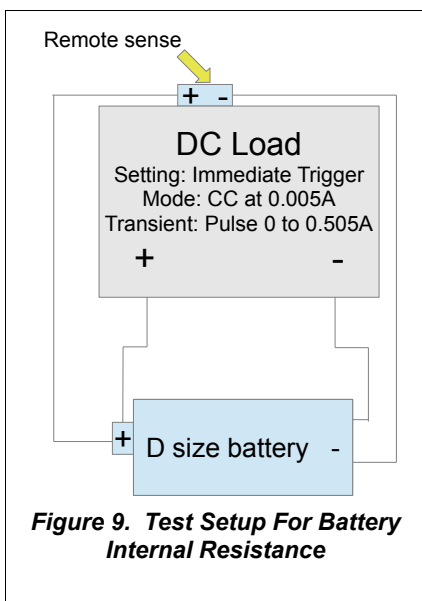

Figure 9. Test Setup For Battery Internal Resistance

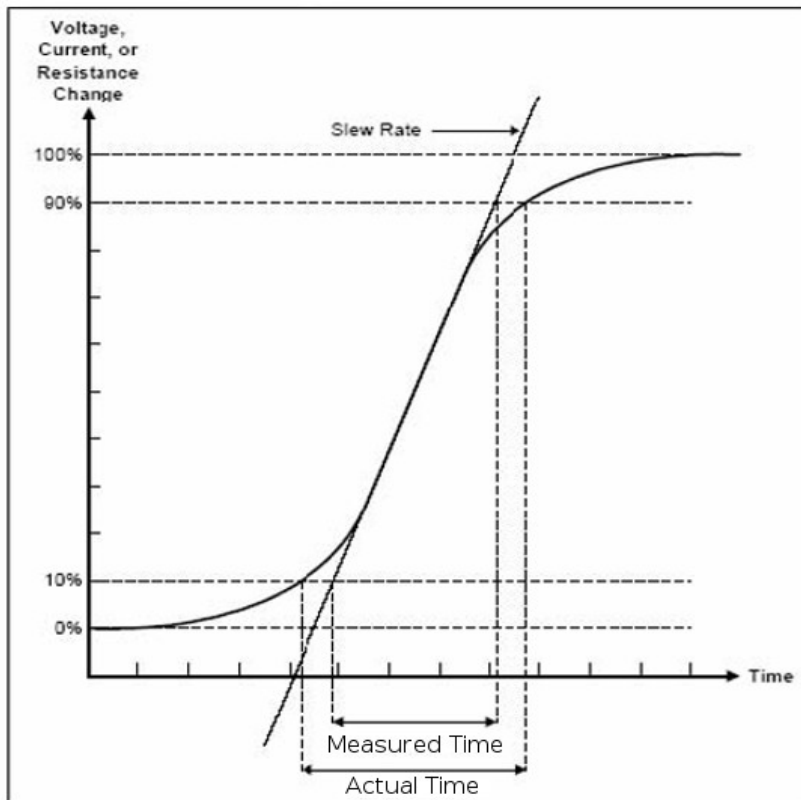

Figure 10. Slew Rate Measurement Graph

2. Adjust trigger level until waveform trace is captured.
3. Adjust vertical and horizontal scale and the trigger level and run once again.
4. Repeat steps 2 and 3 until a good sampled trace is captured.

Results

Observe the trace on the oscilloscope and compare it to Figure 10. Use the scope's cursors to approximate the 10% and 90% mark. Observe the steepest slope in between the cursor lines. A rough estimate can be made by taking the difference of the two cursor lines. Since this setup tests a current transition from 0 A to 120 A, slew rate can be calculated by dividing the change in current over the change in time; that is the difference of the cursors.

OTHER DC LOAD APPLICATIONS

Figure 11. Connect the BNC to binding post adapter into an oscilloscope. Follow the setup below for the DC load and oscilloscope.

DC Load Setup

1. Setup transient mode with current levels from 0 A for 0.5 ms to 120 A for 1000 ms in pulse

mode.

2. Set load to CC mode
3. Turn on input for a short moment. Turn off once oscilloscope setup is complete.

Oscilloscope Setup

1. Set to single run.

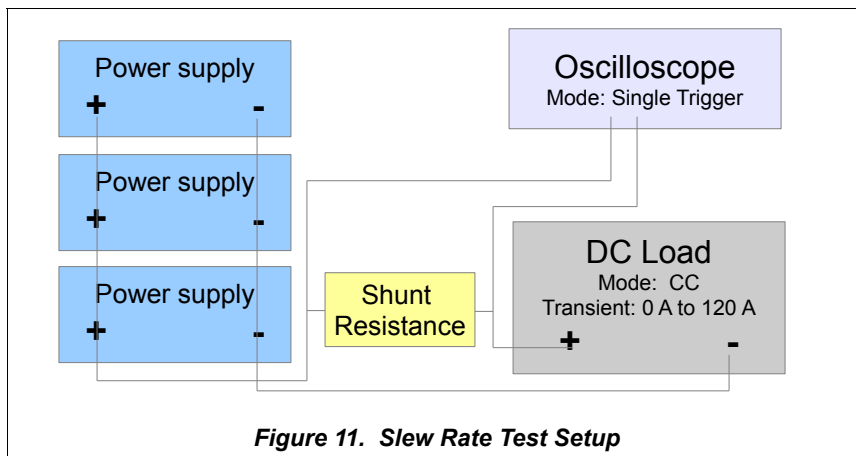

Figure 11. Slew Rate Test Setup

DC loads can be very resourceful for various tests and applications. Sometimes, they may even act as a different type of test instrument for measurement. A good example would be a voltmeter. Other practical applications that will be mentioned in this section is a fuse. DC loads can also act as a fuse in a circuit for monitoring current thresholds

to help prevent possible damage from overcurrent or overpower.

Voltmeter

In any design or test environment, a voltmeter is required in one way or another for measurements. It is one of the most useful test tool today. For this reason, it is often convenient to have a DC load that can read voltages when a voltmeter is not around. For simplicity, a test program script has been provided under "Software Examples" at the end of the note under section labeled "Voltmeter Reading" to perform simple voltage measurements and reading rates of B&K Precision's 8500 DC load. This load can measure with a millivolt resolution before indicating an overrange. Refer to the section for detailed information on setting up and running the software application.

Fuse

The application described in this section is to demonstrate how to use a DC load as a fuse in a circuit. Under program control, the load can shut off when either current, voltage, or power measured exceeds a set value in the load. This is a basic application for a fuse, and due to some delays from the software control, it is not recommended for use if fast responses are required. The

program codes to run this application can be found in the "Software Examples" section under "Fuse Application". Details of usage and operation are provided in the same section.

Setup

Connect load in series with a circuit. Be sure that remote sense is off. Run the program to monitor current. Threshold value is set in the program.

Note: The DC load does not behave like a pure resistance. For this fuse application, it may be hard to test low currents in the few mA range. For example, on B&K Precision's 8500 load, there is a turn-on threshold voltage of around 0.1 volts before the load starts conducting current and, thus, it may jump past a low current setting. Thus, please test this fuse application carefully before using it to protect valuable circuitry.

SOFTWARE EXAMPLES

The following sections include the source codes for all software based applications and examples previously mentioned. If not done already, please read the documentation provided from

B&K Precision's website at: <http://www.bkprecision.com/products/dc-electronic-loads/8500-300-w-programmable-dc-electronic-load.html> for successful installation of the python libraries. This **must** be set up correctly prior to using any of the source codes provided in this note. Be sure to also read the instructions under each software example for correct usage.

Battery Discharge Test

The objective of this program is to characterize the discharge curves of common household batteries. It can be used to monitor and log data when a battery is discharged by one of B&K Precision's 8500 series DC loads.

Instructions

There are two settings that can be modified in the code to cater particular test settings. These two settings are the interval between each reading, defined as "interval_s" in beginning of the program, and baudrate, defined as "baudrate" at the end of `main()`. By default, `interval_s = 1` and `baudrate = 38400`.

To run the command, lets use the example given previously.

```
python battery.py 5 cc 0.5 0.5 aa_test 78deg F
```

The above command is in a specific order, which is read as port 5, CC mode, 0.5 A in CC mode, 0.5 V cut off voltage, filename to save data as "aa_test.dat", and extra strings added at the end of each record is "78deg F". Refer to Table 2 below for detailed instructions.

Note: The program will NOT overwrite any existing data files.

Run command	Python file name	Port #	Mode:	Decimal value for constant mode	Cut off voltage	Filename of recorded data	Any string to attach at end of each line
python	Name of the python program	COM port # used to connect to PC	cc: constant current cv: constant voltage cp: constant power cr: constant resistance	Any value set for the respective mode. (i.e. 0.5 in cc mode is 0.5 A, 2 in cv mode is 2 V)	Decimal value of cut off voltage to end program	Files are saved in same folder as the python program file with .dat extension	Any strings of text can be added for reference

Table 2. Instructions on Command for Battery Discharge Test Script

battery.py

<pre>Data file: Header info: # Command line # Date and time for start of test Entry info: time voltage current power time is in seconds since start of test Other measurements are in V, A, and W We talk to a DC load using COM. ''' import sys, dclload from win32com.client import Dispatch from string import join from time import time, sleep from msvcrt import kbhit, getch out = sys.stdout.write nl = "\n" interval_s = 1 # Interval between readings def Usage(): name = sys.argv[0]</pre>	<pre>msg = """Usage: %(name)s port mode value cov filename [docstring] Test a battery with a DC load until the specified cut-off voltage is reached. Arguments are: port COM port that the load is at. mode cc for constant current cv for constant voltage cp for constant power cr for constant resistance value Decimal value of desired constant mode value. cov Cut-off voltage in volts. filename Data will be stored in filename.dat. docstring Any further text is just logged to the data file. ''' % locals() print msg exit(1) def ProcessCommandLine(): if len(sys.argv) < 6:</pre>
---	---

```

Usage()
port = int(sys.argv[1])
mode = sys.argv[2]
value = float(sys.argv[3])
cov = float(sys.argv[4])
filename = sys.argv[5] + ".dat"
docstring = ""
if len(sys.argv) > 6:
    docstring = join(sys.argv[6:])
# Check values
assert(port >= 0)
assert(mode in ("cc", "cv", "cp", "cr"))
assert(value > 0)
assert(cov > 0)
from os.path import exists
assert(not exists(filename))
out("Mode = %s\n" % mode)
out("Value = %s\n" % value)
out("cov = %s\n" % cov)
out("filename = %s\n" % filename)
return port, mode, value, cov, filename, docstring

def Set(task, error_message):
    if error_message:
        out("Error on task '%s':\n" % task)
        out(error_message)
        exit(1)

def SetModeAndValue(load, mode, value):
    # Set mode and value. Also check that the maximum setting is at
    # least the value we want.
    Set("Set to mode %s" % mode, load.SetMode(mode))
    if mode == "cc":
        max_current = float(load.GetMaxCurrent())
        if max_current < value:
            out("Max current setting is less than desired value" + nl)
            exit(1)
        Set("Set to value %g" % value, load.SetCCCurrent(value))
    elif mode == "cv":
        max_voltage = float(load.GetMaxVoltage())
        if max_voltage < value:
            out("Max voltage setting is less than desired value" + nl)
            exit(1)
        Set("Set to value %g" % value, load.SetCVVoltage(value))
    elif mode == "cp":
        max_power = float(load.GetMaxPower())
        if max_power < value:
            out("Max power setting is less than desired value" + nl)
            exit(1)
        Set("Set to value %g" % value, load.SetCWPpower(value))
    else:
        Set("Set to value %g" % value, load.SetCRRResistance(value))

def GetCurrentVoltagePower(load):
    def get_value(f):
        value, unit = f.split()
        return float(value)
    s = load.GetInputValues()
    fields = s.split("\t")
    voltage = get_value(fields[0])
    current = get_value(fields[1])
    power = get_value(fields[2])
    return voltage, current, power

def RunTest(log, load, mode, value, cov):
    def LogMsg(msg):
        out(msg)
        log(msg)
    load.SetRemoteControl()
    SetModeAndValue(load, mode, value)

log("# Command line: %s\n" % join(sys.argv[1:]))
log("# %s\n" % version)
msg = "# Test start time = " + load.TimeNow() + nl
LogMsg(msg)
Set("Turn load on", load.TurnLoadOn())
voltage, current, power = GetCurrentVoltagePower(load)
start_time = time()
while voltage >= cov:
    voltage, current, power = GetCurrentVoltagePower(load)
    current_time = time() - start_time
    LogMsg("%9.2f %9.4f %8.4f %9.4f\n" % \
           (current_time, voltage, current, power))
    sleep(interval_s)
    if kbhit():
        c = getch()
        if c == "Q":
            break
Set("Turn load off", load.TurnLoadOff())
LogMsg("# Test finish time = " + load.TimeNow() + nl)
load.SetLocalControl()

def main():
    port, mode, value, cov, filename, docstring = ProcessCommandLine()
    load = Dispatch('BKServers.DCLoad85xx')
    baudrate = 38400
    load.Initialize(port, baudrate) # Open a serial connection
    log = open(filename, "w").write
    RunTest(log, load, mode, value, cov)

main()

```

Voltmeter Reading

In this section, the codes provided below are used for the "voltmeter" application using the DC load. It provides a convenient and remote way to collect voltage readings into a data file to serve its purpose.

Instructions

Two settings must be configured correctly to run the script. They are port and baudrate. In the code of *voltmeter.py*, they are declared at the beginning as "port = 5" and "baudrate = 38400" by default. Please change the values to match the port and baudrate settings used to interface on the PC. *Note: The DC load must have the same baudrate configurations as in the code, and port number has to match the COM port on the PC used to connect to DC load.*

voltmeter.py

```
import sys, dclload
from time import time
from win32com.client import Dispatch
from msvcrt import kbhit

port = 5
baudrate = 38400

load = Dispatch('BKServers.DCLoad85xx')
load.Initialize(port, baudrate) # Open a serial connection
load.SetRemoteControl()
of = open("fast.dat", "w")
start = time()
count = 1
while True:
    msg = "%6d %8.2f s  %s\n" % (count, time() - start, load.GetInputValues())
    of.write(msg)
    if kbhit():
        break
    count += 1
finish = time() - start
load.SetLocalControl()
of.write("\nReading rate = %.1f readings/second\n" % (count/finish))
print "\nReading rate = %.1f readings/second\n" % (count/finish)
```

Fuse Application

A practical feature in most DC loads is the overpower, overcurrent, and overvoltage protection. With this, a DC load can behave like a fuse in a circuit, monitoring current, voltage, or power from exceeding design specifications of the circuit. An excellent way to demonstrate this application is to use a program. Provided in the following is an example python script for monitoring current using B&K Precision's 8500 DC load.

Instructions

Two settings must be configured correctly to run the script. They are port and baudrate. In the code of *voltmeter.py*, they are declared at the beginning as "port = 5" and "baudrate = 38400" by

default. Please change the values to match the port and baudrate settings used to interface on the PC.

Here's an example to run the command:

```
python fuse.py 5
```

The value "5" represents the fuse value to set. In this example, it is 5 A. With slight modifications to the script, the program can also monitor voltage and power.

fuse.py

```
import sys, dclload
from time import time
from win32com.client import Dispatch
from msvcrt import kbhit

port = 5
baudrate = 38400

def ReadCurrent(load):
    fields = load.GetInputValues().split("\t") # Split on tab characters
    current = float(fields[0].split()[0]) # Remove the "A"
    return current

def main():
    # Check the command line
    if len(sys.argv) != 2:
        print "Usage: %s fuse_value_in_A" % sys.argv[0]
        exit(1)
    # Get the desired fuse value from the command line
    fuse_value_A = float(sys.argv[1])
    assert(fuse_value_A > 0)
    # Establish a load connection
    load = Dispatch('BKServers.DCLoad85xx')
    load.Initialize(port, baudrate) # Open a serial connection
    load.SetRemoteControl()
    load.SetMode("cc") # Set to constant current mode
    load.SetCCCurrent(fuse_value_A) # We won't exceed this value
    load.TurnLoadOn()
    current = ReadCurrent(load)
    while current < fuse_value_A:
        if kbhit(): break
        current = ReadCurrent(load)
    load.TurnLoadOff()
    load.SetLocalControl()

main()
```

Reference

- [1] <http://data.energizer.com/PDFs/BatteryIR.pdf> A technical bulletin on internal resistance.