



Non-contact Probing of RF Circuits with the Beehive 100 Series Probes



Introduction

As RF products become more integrated, testing them becomes for difficult. High levels of integration reduce the number of separate assemblies in an RF system, frequently integrating the entire product into one printed circuit board. Because cables and coaxial connectors have been eliminated, it is no longer possible to simply connect test equipment to a suspect circuit through a coaxial cable.

For example, when it was necessary to test the local oscillator in a microwave transmitter, one could previously connect a spectrum analyzer to the oscillator's output and measure the signal power and frequency directly. Today, the entire signal chain might be integrated on one printed circuit board, with the only accessible RF interconnect being the connection between the transmitter and the antenna.

For these reasons, various probes and probing techniques have been developed to allow technicians and engineers to measure RF signals on the printed circuit board itself. This article highlights the advantages of using passive non-contact probes for this work.

Contact vs. non-contact probes

Most high frequency probes are contact probes. In other words, they rely on a direct electrical connection between the probe and the circuit to be measured. This technique works, but suffers from several disadvantages: Loading, ground inductance, and usability.

Loading: A typical high-frequency active probe has a relatively high DC resistance, but a capacitance in the range of 0.5 to 1.0 pF. While this capacitance is acceptable at low frequencies, at RF it can pose a significant problem. For example, 1 pF represents a shunt reactance of 80 ohms at 2 GHz. Passive probes may have lower capacitance, but at the price of significantly lower resistive loading; often as low as 1000 ohms.

In contrast, non-contact probes have no DC loading at all. Because they do not actually touch the circuit under test, their capacitive loading is also extremely low.

Ground inductance: A ground connection is required for contact probes. Making this connection, however, can be quite difficult. A long ground wire will add excessive inductance to the probe, resulting in a poor frequency response. A very short ground wire is necessary at RF frequencies. However, very short ground connections are very difficult to work with.

Usability: These very short ground connections are one of the things that make high frequency active probes difficult to use. Rather than a clip lead, a short, stiff ground probe is usually part of the probe tip. Anyone who has ever used these knows how difficult it is to simultaneously make a signal and ground connection with their probe using one hand, while using the other hand to operate equipment and make measurements. It takes the skill of a surgeon hold the probe steady enough so that contact is maintained; if the probe slips it could inadvertently short the circuit under test to ground, possibly destroying it.

Non-contact probes solve all three of these problems. Since there is no direct connection between the circuit and the probe, loading is extremely small. Since there is no ground lead, ground inductance is not an issue. And, since the probe tips are insulated, accidental shorts are impossible.

E-field vs. H-field probes

Non-contact probes do not measure voltage or current directly. Rather, they measure the electromagnetic fields that surround a conductor.

E-field probes measure the electric field around the conductor; the magnitude of the E-field is proportional to the conductor's voltage. H-field probes measure the magnetic field around a conductor; the magnitude of the H-field is proportional to the conductor's current.

At low frequencies, the impedance of a circuit node can be very high or very low, and as a result the relative magnitude of the E and H fields can vary. In a high-impedance circuit, the voltage is relatively high and the current is relatively low; in this situation an E-field probe will display better sensitivity. In a low-impedance circuit, the situation is reversed.

As frequencies climb into the RF range, these extremes of impedance are no longer practical to realize, and there is less possible sensitivity difference between E and H field probes. However, the different types of probes still have unique characteristics. The primary advantage of E-field probes is their fine spatial resolution. Since they have a narrow tip, it's possible to isolate signals down to specific pins on an IC. H-field probes, since they have a circular loop for their tip, are less proficient at this. A smaller loop will offer better spatial resolution, but at the cost of reduced sensitivity. A larger loop will have better sensitivity, but will have less accurate spatial resolution as well as less accurate high-frequency response. For this reason, Beehive Electronics sells a series of H-field probes with different loop sizes, allowing the user to select the optimum probe for the frequency of interest.

The disadvantage of E-field probes is common-mode currents. A source of electric fields can induce a current to flow in the probe, but also can induce a current to flow on the outer conductor of the probe's coaxial launch. These surface currents can be affected by, for example, placement of the user's hand, causing a lack of repeatability in the measurements. In poorly designed probes, this effect can cause a variance of several dB as the user moves his hand along the probe. Beehive's 100D E-field probe is designed to minimize this effect, so the variation is less significant. Beehive's 100A/B/C H-field probes have integrated electric-field shields, so they are essentially immune to this problem.

Example measurement of two-port devices

To demonstrate the feasibility of using non-contact probes for RF troubleshooting, the test circuit shown below was measured.

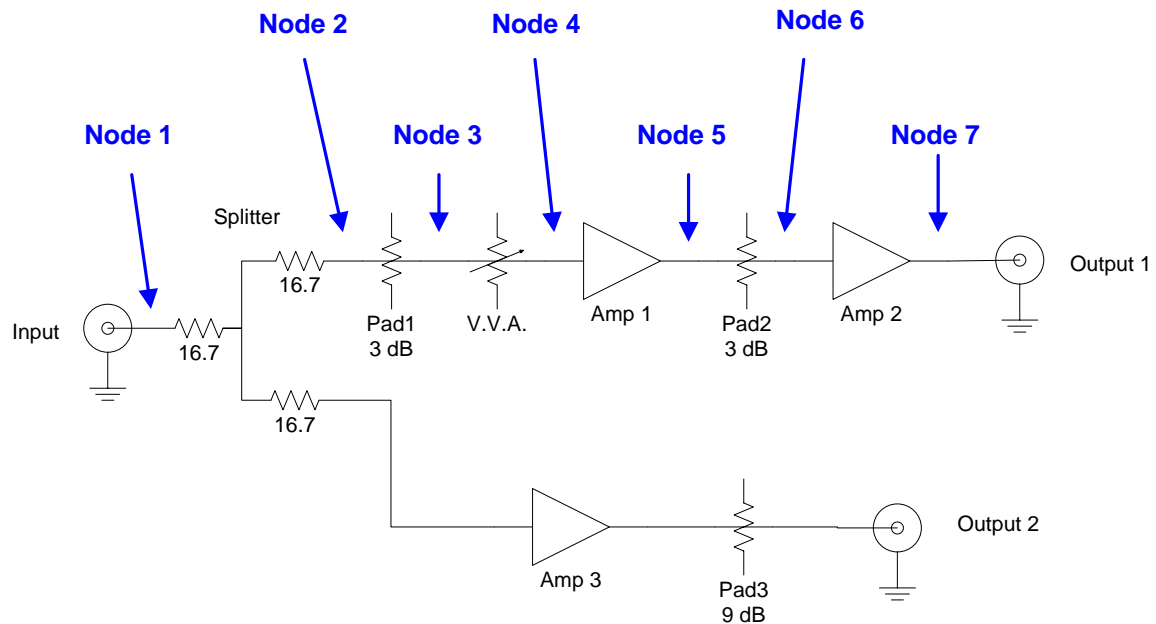

Test Circuit Block Diagram

A signal generator was connected to the input; the input signal had a frequency of 1 GHz and an amplitude of 0 dBm. The RF output connectors were terminated with 50 ohm loads. A Beehive Electronics 100D E-field probe was used to measure the signal levels through the signal path between the input and Output 1. The following photo shows the setup:

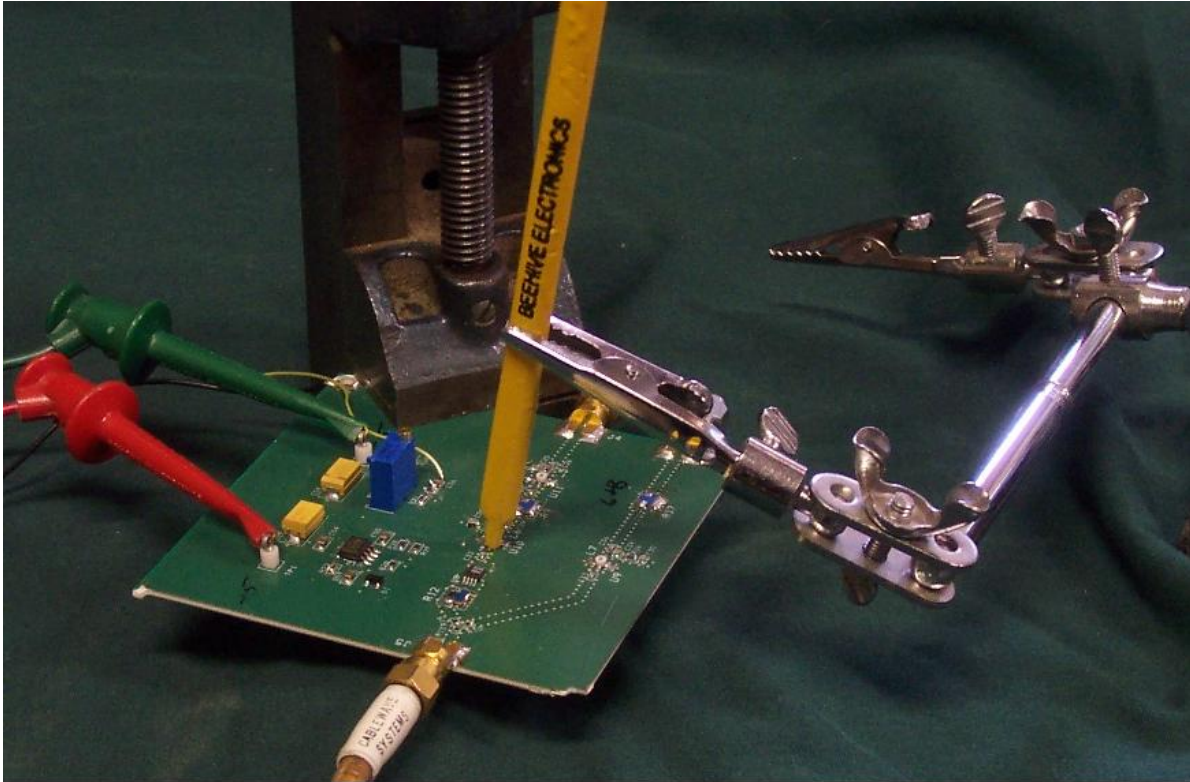

Although the photo shows the probe being held with an alligator clip, the probe was actually hand-held when the measurements were made. At each of the nodes labeled in the block diagram, a measurement was made using the 100D probe. The probe output was attached to a spectrum analyzer tuned to 1 GHz.

The measurements made at each point were compared to the expected value. For example, if the power level measured with the probe was -40 dBm at node 1, we would expect the power level measured at node 2 to be -46 dBm, based on the nominal 6 dB loss of the splitter.

The following graph shows the measured and predicted signal levels throughout the signal chain.

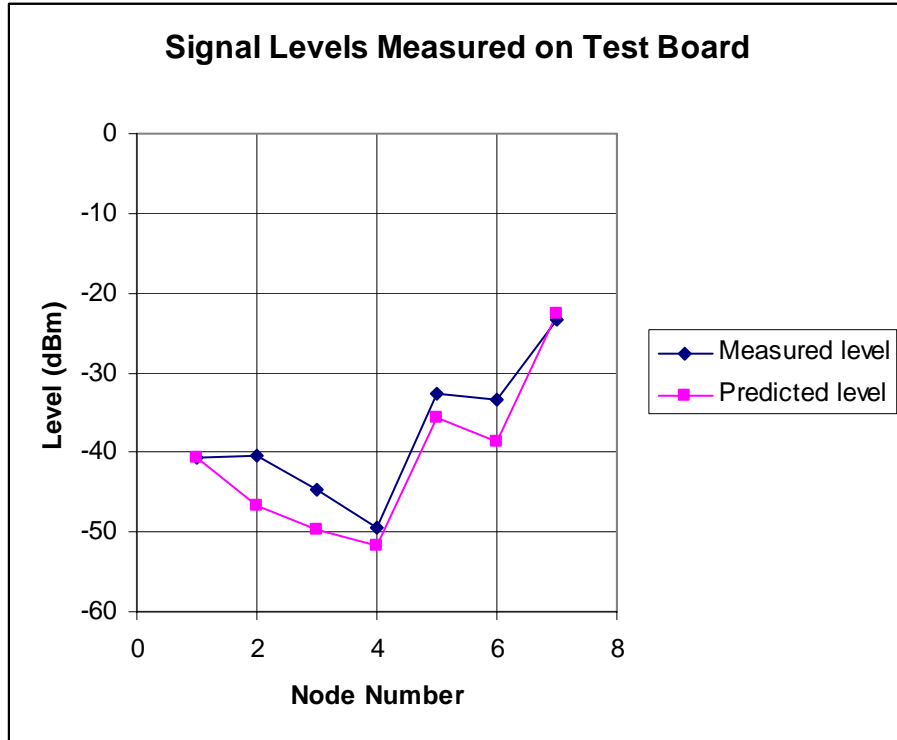

Overall, we can see that the measured signal levels follow the predicted levels throughout the chain, with a node-to-node error of a few dB.

Next, we induced a fault in the board. We disconnected the power supply from amplifier #1. This simulates a fault that one might typically see on a production PCB, where a bad solder joint could cause an open circuit in an amplifier's bias network. The measurements were then repeated at each of the nodes. The results are shown in the graph below.

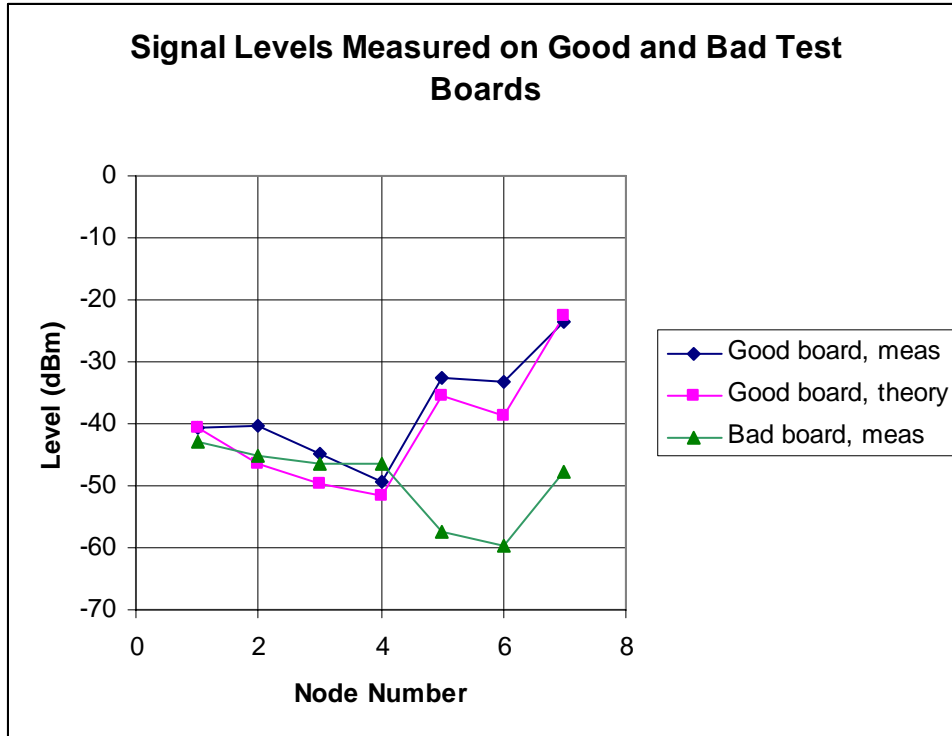

Here we can see a dramatic difference in the signal levels starting at node 5, the output of amplifier #1. It's clear that the measurement repeatability of the non-contact E-field measurement is sufficient to track down the fault.

The power of this technique becomes particularly obvious when considering the time involved. No time is required to break the signal chain or to solder probes to the PCB. No care need be taken to find or create nearby ground connections. The total time to measured the signal level across all seven nodes and find the defective part was approximately *one minute*.

Calibrated non-contact measurements

The previous example used relative power measurements. The faulty amplifier was identified by comparing the power level at the input to the amplifier and at the output. However, sometimes it is desirable to make an absolute power measurements. For example, an oscillator is a one-port device. Without an input port to establish a reference, it's difficult to predict what power level one might expect when measuring the oscillator output with a probe.

To this end, we measured the coupling between microstrip lines and the Beehive probes for microstrip lines of several thicknesses. 50 ohm lines were fabricated on 0.016", 0.031", and 0.062" thick FR4 with on-board 50 ohm terminations. The coupling factor between the line and probe was measured using a vector network analyzer. A photo of the test setup is shown below.

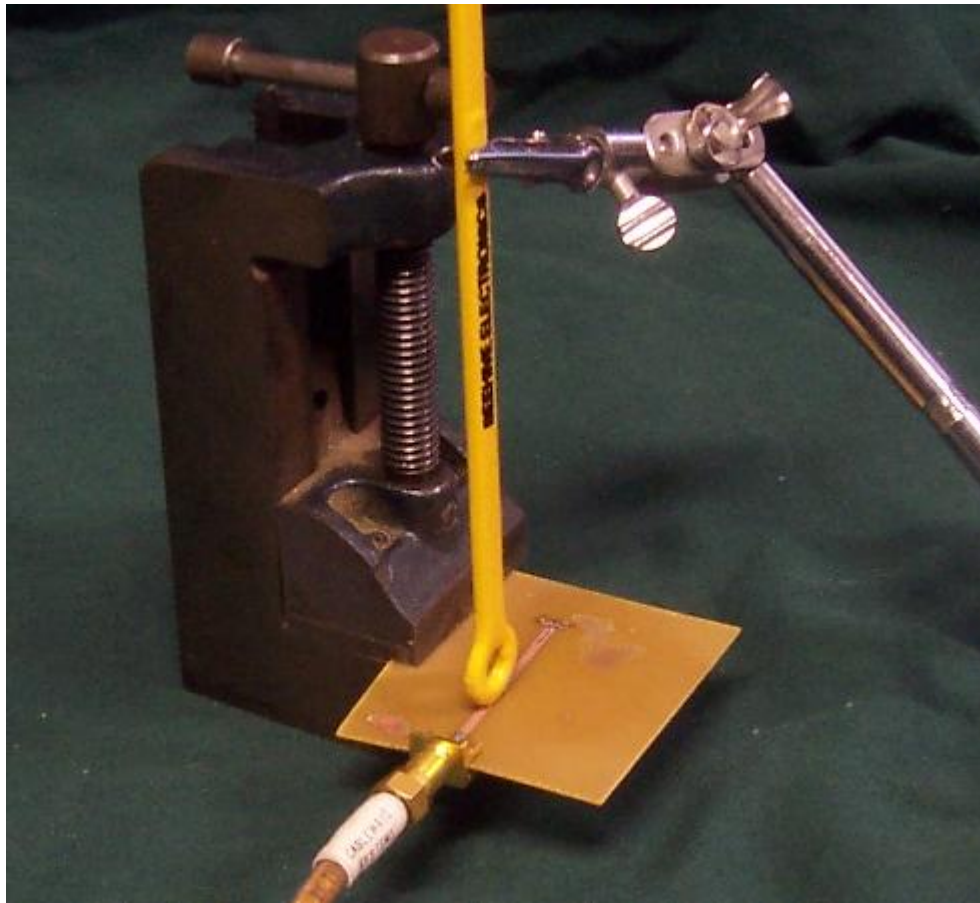

The photo shows a 100A H-field probe measuring the power on the 50 ohm line. Port one of the network analyzer was connected to the test board, and port two of the network analyzer was connected to the probe. Note that, unlike E-field probes, H-field probes are directional. Maximum coupling occurs when the plane of the loop is aligned with the microstrip trace.

Coupling was measured for each probe to transmission lines on each of the three substrates. The results are shown below. Note that the frequency range of the measurements differ for the various probes, depending on the frequency range of the probe itself. The 100C H-field probe has a large loop area, making it most sensitive at low frequencies. However, at higher frequencies the loop reaches resonance, limiting its useful frequency range to a few hundred Megahertz.

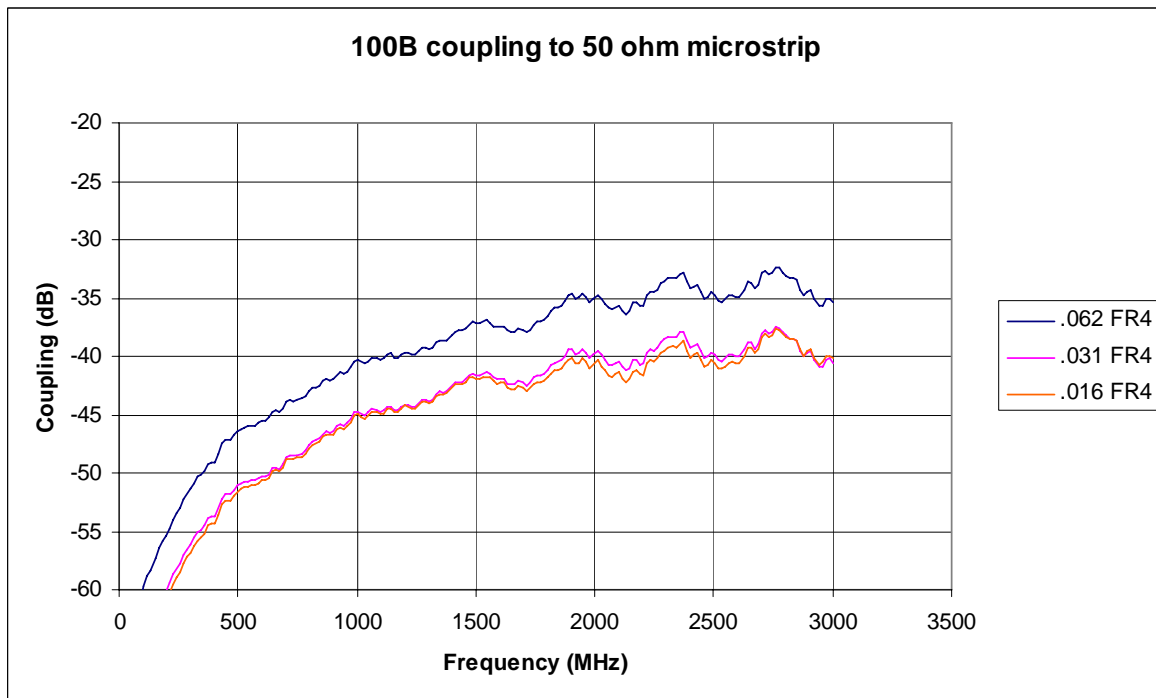
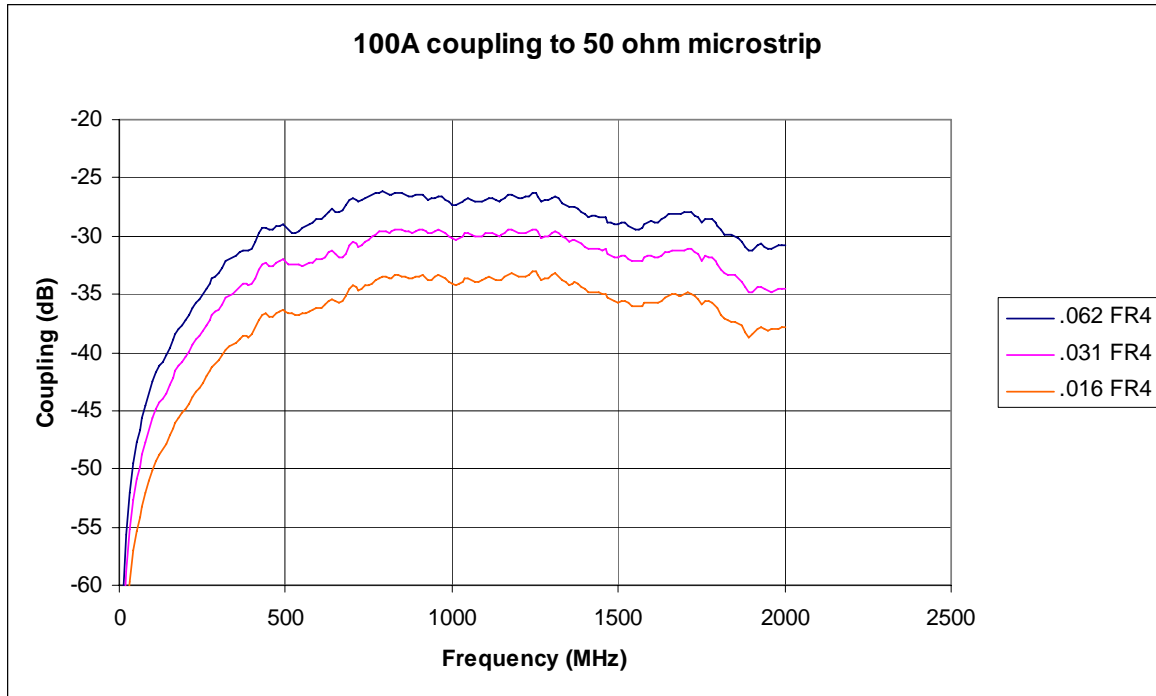

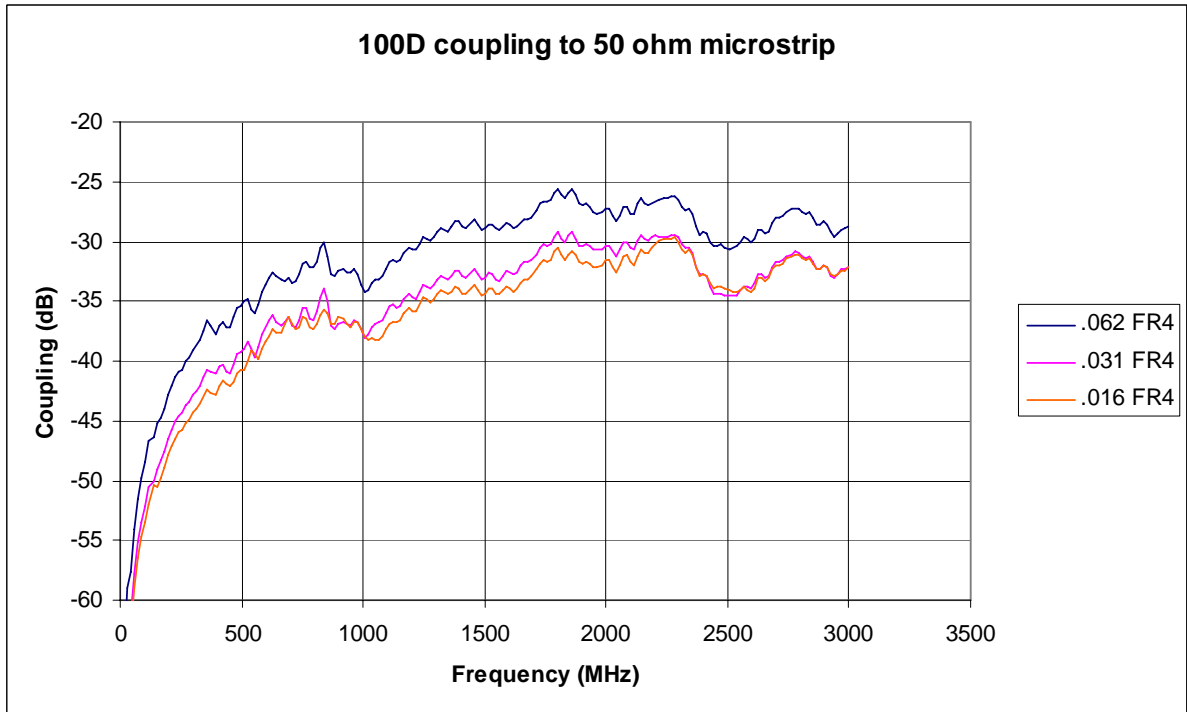
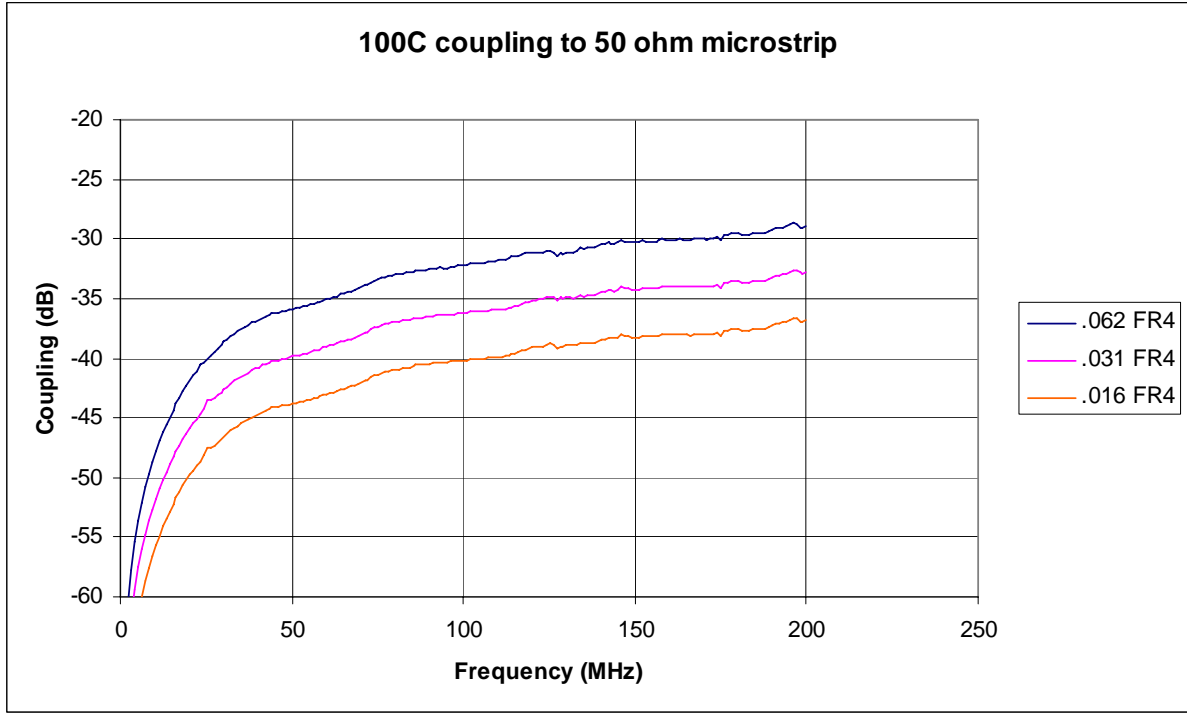

An example will illustrate the use of these graphs. Suppose that we want to measure the output power of a 1 GHz oscillator. The oscillator is fabricated on 0.062" FR4 with a bottom-side ground plane. The nominal output power of the oscillator is +10 dBm. What power level would we expect to see?

At 1 GHz, the 100A H-field probe is a good choice. It has an intermediate-sized loop. Being smaller than the 100C, it will be better behaved than the 100C at 1 GHz. Being larger than the 100B, it will have better sensitivity.

From the graphs above, we see that the coupling factor between a 100A probe and 0.062" thick microstrip is approximately -27 dB. So, with a +10 dBm signal, we would expect to measure -17 dBm with a 100A probe.

Sensitivity calculation for phase noise measurements

With adequate sensitivity, it is even possible to make high-dynamic range measurements using non-contact probes. For example, it is possible to use the probes to measure phase noise and spurious on an oscillator.

Suppose we want to measure phase noise at a 10 kHz offset on a 3 GHz oscillator using a spectrum analyzer. The phase noise of the oscillator is approximately -80 dBc/Hz at that offset. Will we be able to make the measurement? Will the phase noise sidebands be high enough in power that we will be able to distinguish them from the spectrum analyzer noise floor?

The following table shows the calculations involved.

Frequency	3 GHz
Oscillator power	+10 dBm
Phase noise target	-80 dBc/Hz
100B coupling factor	-35 dB
Spectrum analyzer noise figure	30 dB
Spectrum analyzer noise floor	-144 dBm/Hz
Oscillator power at probe output	-25 dBm
Phase noise sideband power	-105 dBm/Hz
Measurement noise margin	39 dB

Using a 100B probe at 3 GHz, the probe output power will be -25 dBm with an oscillator power of +10 dBm, assuming an 0.062" FR4 substrate. With a phase noise sideband of -80 dBc/Hz, the output power of the sideband will be $-25 - 80 = -105$ dBm/Hz. If the spectrum analyzer has a noise figure of 30 dB, its noise floor will be $30 - 174 = -144$ dBm/Hz. This shows that the measured signal will be 39 dB above the spectrum analyzer noise floor, which is plenty of margin for the measurement.

If we were to place a preamplifier between the probe and the spectrum analyzer, the effective spectrum analyzer noise figure might be reduced to 10 dB, yielding a noise floor of -164 dBm/Hz. With the preamp in place, we can now measure extremely low phase noise sidebands. For example, phase noise sidebands at -119 dBc/Hz would still be 20 dB below the noise floor of the preamp/spectrum analyzer combination.

Again, note the simplicity of these measurements. No soldering, fixturing, or special design features have been added to the circuit under test. The probe is simply held next to the trace, and the measurement is made. Since the probe tip is nonconductive, there is no chance of accidental shorts, even on a densely-packed board.

Conclusions

Non-contact probes offer a rapid and accurate method for measuring signals on RF PCBs. With no special fixturing, they can be rapidly used to trace a signal path and find a defective component. Using the graphs provided in this article, absolute as well as relative power measurements can be made with ease. Furthermore, the sensitivity of the probes is sufficient to make even high-dynamic-range measurements such as phase noise. All this can be done with no special measurement setups or preparation, allowing rapid measurements in both lab and production environments.