



**AVERY
DENNISON**

Fastener
Solutions

5.5" Intermediate Cable Ties Marketing Specifications

For the following part numbers:

08376-0

08383-0

08384-0

08400-0

08431-0

August 1, 2018

AVERY DENNISON MARKETING SPECIFICATION

THE SUBJECT MATTER DISCLOSED HEREIN EMBODIES PROPRIETARY INFORMATION WHICH IS THE CONFIDENTIAL PROPERTY OF THE AVERY DENNISON CO. NONE OF WHICH SHALL BE COPIED, REPRODUCED, DISCLOSED TO OTHERS, PUBLISHED OR USED IN WHOLE OR IN PART, FOR ANY PURPOSE OTHER THAN THAT FOR WHICH IT IS BEING MADE AVAILABLE WITHOUT THE EXPRESS ADVANCE WRITTEN PERMISSION OF A DULY AUTHORIZED AGENT OF THE COMPANY. THIS DOCUMENT IS THE PROPERTY OF THE AVERY DENNISON CO. AND IS TO BE RETURNED TO THE COMPANY ON DEMAND.

HISTORY		
REV.	DATE	DESCRIPTION
Q	09.24.13	UPDATE BALLOON 5; ADDED UNITS
R	09.19.14	ADDED OPER. TEMP, UL LOGO ANDNOTE; CHG DIM 1 TO BE TAKEN FROM THE BOTTOM OF THE HEAD
S	04.17.17	ADDED SPECIAL CHARACTERISTICS; 105.4 WAS DIM 5, CHG TO A REF, ALL BALLOONS AFTER 5 WERE RE-NUMBERED

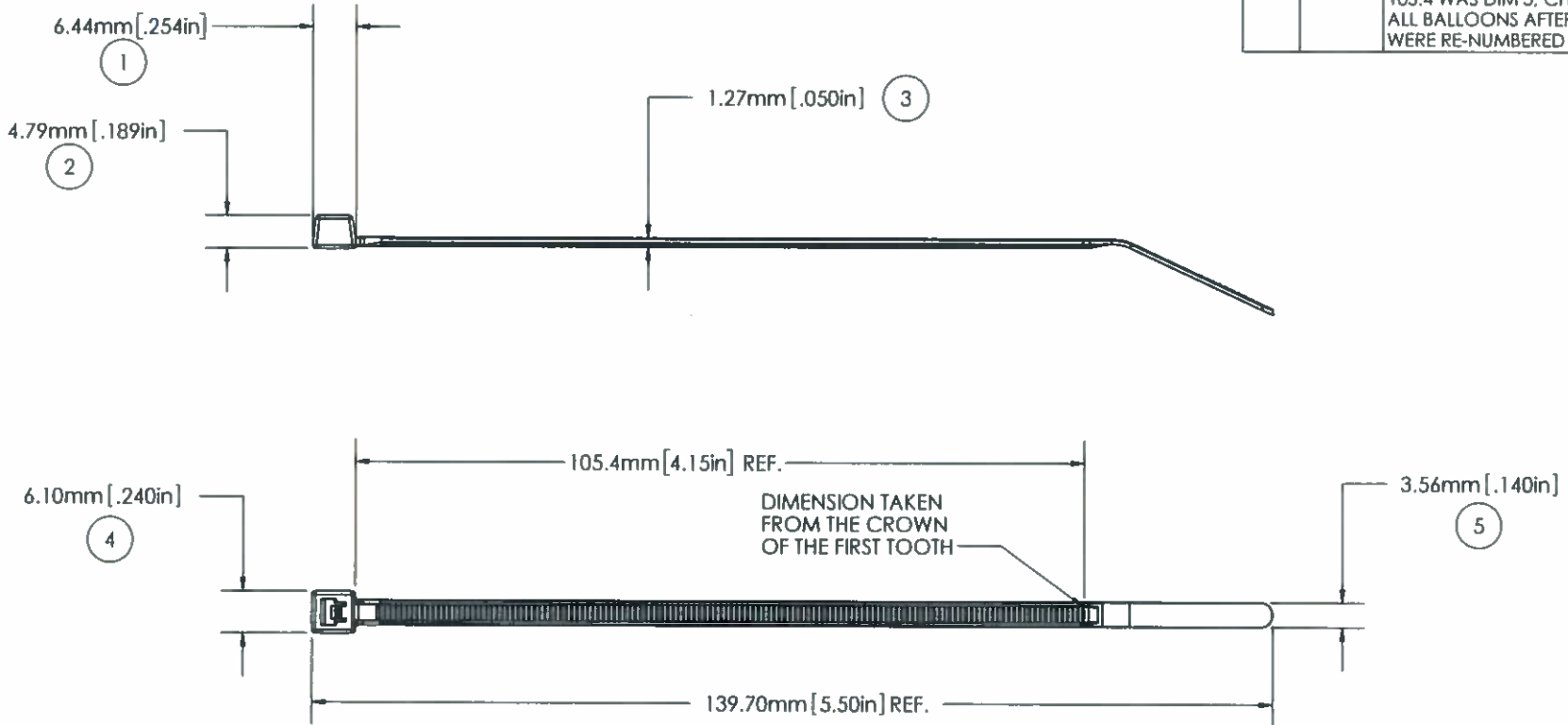

NOTE:
1. SPECIAL CHARACTERISTICS ARE NOTED BY A TRIANGLE (Δ)



⑥	Δ FLAMMABILITY RATING:	HB RATED PER FMVSS302
⑦	Δ TENSILE STRENGTH:	40 LBF /180N MIN. PER AS-23190
	MILITARY STANDARD:	MS-3367-5-9
	OPERATING TEMP:	-40°F(-40°C) TO 185°F(85°C)
	MIN. INSTALLATION TEMP:	32°F(0°C)
	WEIGHT:	0.7g/0.03oz.
	BUNDLE DIAMETER:	Ø 1.6mm TO Ø 31.8mm
	TOOL:	12001 - HAND INSTALLATION TOOL 12500 - PNUM. INSTALLATION TOOL
	TOOL TENSION SETTING:	3-5
	PACKAGING:	1000/BAG, 5000/CASE

APPROVALS: ENG. APPR. *[Signature]* 4/17/17
Q.A. APPR. *[Signature]* 04/17/2017

SPECIFIED TOLERANCES ARE:
.XX ± .03 IN. .X ± .7 mm
.XXX ± .010 IN. .XX ± .25 mm
ANGULAR: ± 2°

MATERIAL
NYLON 6/6
COLOR
NATURAL

AVERY DENNISON <small>FASTENER DIVISION FRITCHBURG, MA 01420 U.S.A. TEL: 1-800-225-5913 FAX: 978-353-8157</small>	
DESCRIPTION	5.5" CABLE TIE, INTERMED.
STOCK NO.	08376-0
REV.	S

AVERY DENNISON MARKETING SPECIFICATION

HISTORY

THE SUBJECT MATTER DISCLOSED HEREIN EMBODIES PROPRIETARY INFORMATION WHICH IS THE CONFIDENTIAL PROPERTY OF THE AVERY DENNISON CO. NONE OF WHICH SHALL BE COPIED, REPRODUCED, DISCLOSED TO OTHERS, PUBLISHED OR USED IN WHOLE OR IN PART, FOR ANY PURPOSE OTHER THAN THAT FOR WHICH IT IS BEING MADE AVAILABLE WITHOUT THE EXPRESS ADVANCE WRITTEN PERMISSION OF A DULY AUTHORIZED AGENT OF THE COMPANY. THIS DOCUMENT IS THE PROPERTY OF THE AVERY DENNISON CO. AND IS TO BE RETURNED TO THE COMPANY ON DEMAND.

REV.	DATE	DESCRIPTION
D	09.24.13	UPDATE BALLOON 5; ADDED UNITS
E	09.18.14	ADDED OPER. TEMP, UL LOGO ANDNOTE: CHG DIM 1 TO BE TAKEN FROM THE BOTTOM OF THE HEAD
F	04.17.17	ADDED SPECIAL CHARACTERISTICS; 105.4 WAS DIM 5, CHG TO A REF, ALL BALLOONS AFTER 5 WERE RE-NUMBERED

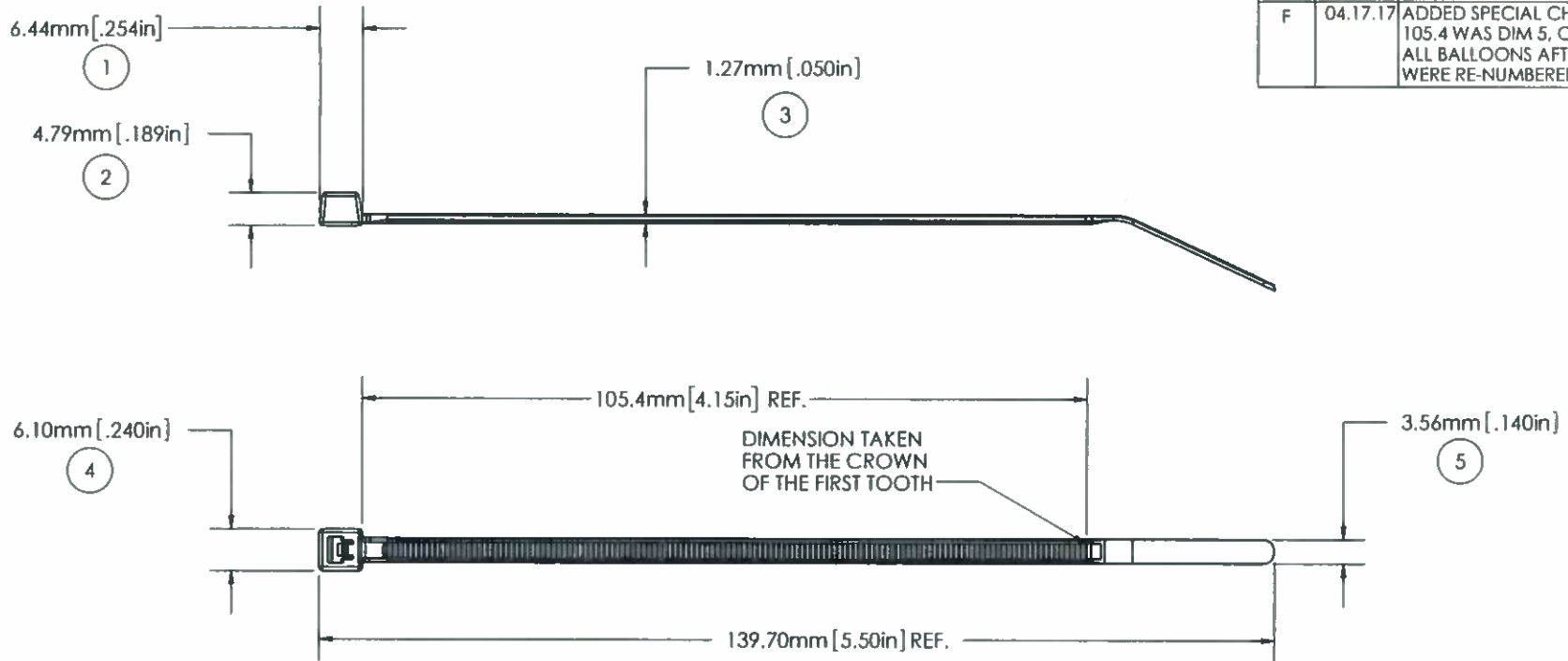

NOTE:
1. SPECIAL CHARACTERISTICS ARE NOTED BY A TRIANGLE (Δ)



⑥ Δ	FLAMMABILITY RATING:	HB RATED PER FMVSS302
⑦ Δ	TENSILE STRENGTH:	40 LBF / 180N MIN. PER AS-23190
	MILITARY STANDARD:	MS-3367-5-9
	OPERATING TEMP:	-40°F (-40°C) TO 185°F (85°C)
	MIN. INSTALLATION TEMP:	32°F (0°C)
	WEIGHT:	0.7g/0.025oz.
	BUNDLE DIAMETER:	\varnothing 1.6mm TO \varnothing 31.8mm
	TOOL:	12001 - HAND INSTALLATION TOOL 12500 - PNEUM. INSTALLATION TOOL
	TOOL TENSION SETTING:	3-5
	PACKAGING:	100/BAG, 5000/CASE

APPROVALS:	ENG. APPR.	<i>[Signature]</i> 4/17/17
	Q.A. APPR.	<i>Caitlin Wallencout</i> 4/17/17

SPECIFIED TOLERANCES ARE:	
.XX \pm .03 IN.	.X \pm .7 mm
.XXX \pm .010 IN.	.XX \pm .25 mm
ANGULAR: \pm 2°	

MATERIAL	NYLON 6/6
COLOR	NATURAL

AVERY DENNISON <small>FASTENER DIVISION FRITCHBURG, MA 01420 U.S.A. TEL. 1-800-225-5913 FAX. 978-353-8157</small>	
DESCRIPTION	
5.5" CABLE TIE, INTERMED.	
STOCK NO.	08383-0
REV.	F

5

4

3

2

1

AVERY DENNISON MARKETING SPECIFICATION

HISTORY

THE SUBJECT MATTER DISCLOSED HEREIN EMBODIES PROPRIETARY INFORMATION WHICH IS THE CONFIDENTIAL PROPERTY OF THE AVERY DENNISON CO. NONE OF WHICH SHALL BE COPIED, REPRODUCED, DISCLOSED TO OTHERS, PUBLISHED OR USED IN WHOLE OR IN PART, FOR ANY PURPOSE OTHER THAN THAT FOR WHICH IT IS BEING MADE AVAILABLE WITHOUT THE EXPRESS ADVANCE WRITTEN PERMISSION OF A DULY AUTHORIZED AGENT OF THE COMPANY. THIS DOCUMENT IS THE PROPERTY OF THE AVERY DENNISON CO. AND IS TO BE RETURNED TO THE COMPANY ON DEMAND.

REV.	DATE	DESCRIPTION
D	09.24.13	UPDATE BALLOON 5; ADDED UNITS
E	09.22.14	ADDED OPER. TEMP, UL LOGO AND NOTE; CHG DIM 1 TO BE TAKEN FROM THE BOTTOM OF THE HEAD

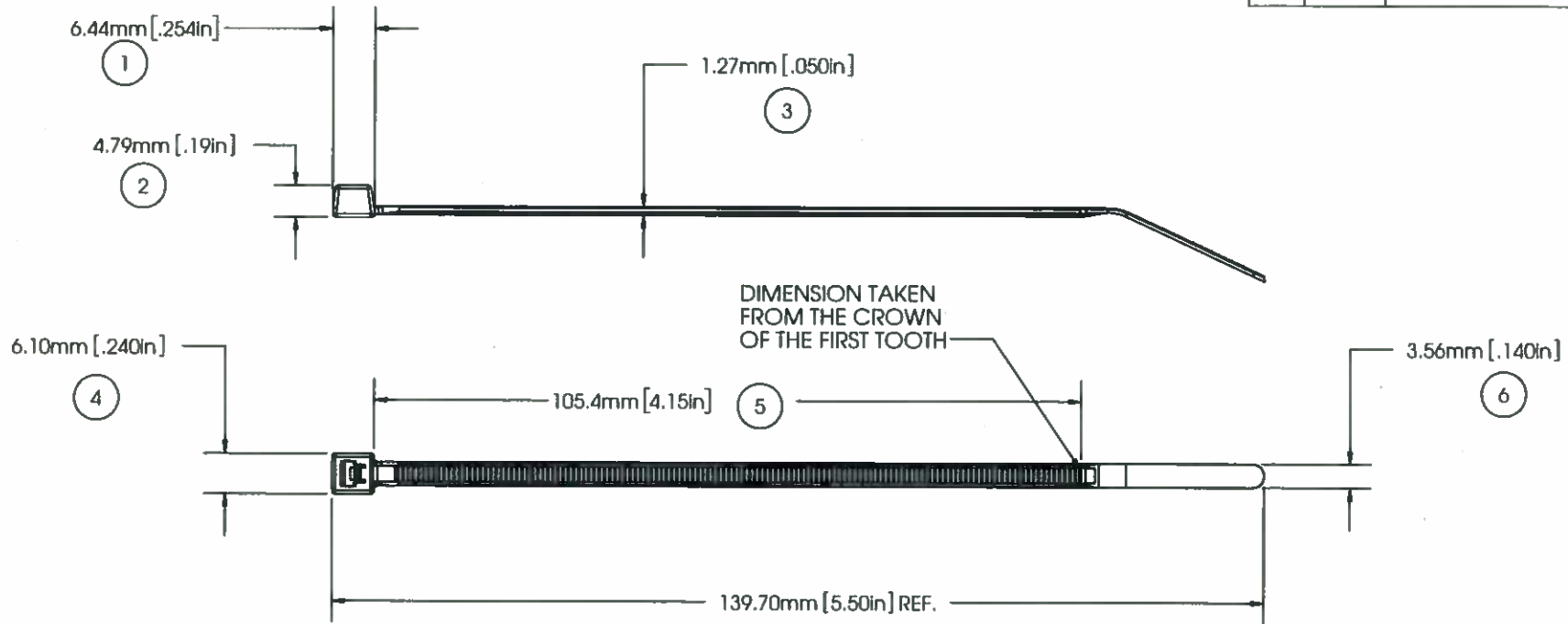

NOTE: THESE CABLE TIES ARE UV RESISTANT AND HAVE A FLAMMABILITY RATING OF V-2



MILITARY STANDARD:	MS-3367-5-0
LOOP TENSILE STRENGTH:	40 LBF /180N MIN. PER AS-23190
OPERATING TEMP:	-40°F(-40°C) TO 176°F(80°C)
MIN. INSTALLATION TEMP:	32°F(0°C)
WEIGHT:	0.025 OZ./0.70 GRAMS
BUNDLE DIAMETER:	Ø 1.6MM TO Ø 31.8MM
TOOL:	12001 - HAND INSTALLATION TOOL 12500 - PNUEM. INSTALLATION TOOL
TOOL TENSION SETTING:	3-5
PACKAGING:	100/BAG, 5000/CASE

APPROVALS:	ENG. APPR. <i>W. J. [Signature]</i> 9/22/14
	Q.A. APPR. <i>J. Boell</i> 9/23/14
SPECIFIED TOLERANCES ARE:	
.XX ± .03 IN.	.X ± .7 MM
.XXX ± .010 IN.	.XX ± .25 MM
ANGULAR: ± 2°	

MATERIAL	NYLON 6/6, WEATHER RESISTANT
COLOR	BLACK

AVERY DENNISON <small>FASTENER DIVISION FITCHBURG, MA 01420 U.S.A. TEL. 1-800-225-5913 FAX. 978-353-8157</small>	DESCRIPTION	5.5" CABLE TIE, INTERMED.
	STOCK NO.	08384-0
REV.	E	

5

4

3

2

1

AVERY DENNISON MARKETING SPECIFICATION

HISTORY

THE SUBJECT MATTER DISCLOSED HEREIN EMBODIES PROPRIETARY INFORMATION WHICH IS THE CONFIDENTIAL PROPERTY OF THE AVERY DENNISON CO. NONE OF WHICH SHALL BE COPIED, REPRODUCED, DISCLOSED TO OTHERS, PUBLISHED OR USED IN WHOLE OR IN PART, FOR ANY PURPOSE OTHER THAN THAT FOR WHICH IT IS BEING MADE AVAILABLE WITHOUT THE EXPRESS ADVANCE WRITTEN PERMISSION OF A DULY AUTHORIZED AGENT OF THE COMPANY. THIS DOCUMENT IS THE PROPERTY OF THE AVERY DENNISON CO. AND IS TO BE RETURNED TO THE COMPANY ON DEMAND.

REV.	DATE	DESCRIPTION
Q	09.24.13	UPDATE BALLOON 5; ADDED UNITS
R	09.12.14	ADDED OPER. TEMP. UL LOGO AND NOTE; CHG DIM 1 TO BE TAKEN FROM THE BOTTOM OF THE HEAD

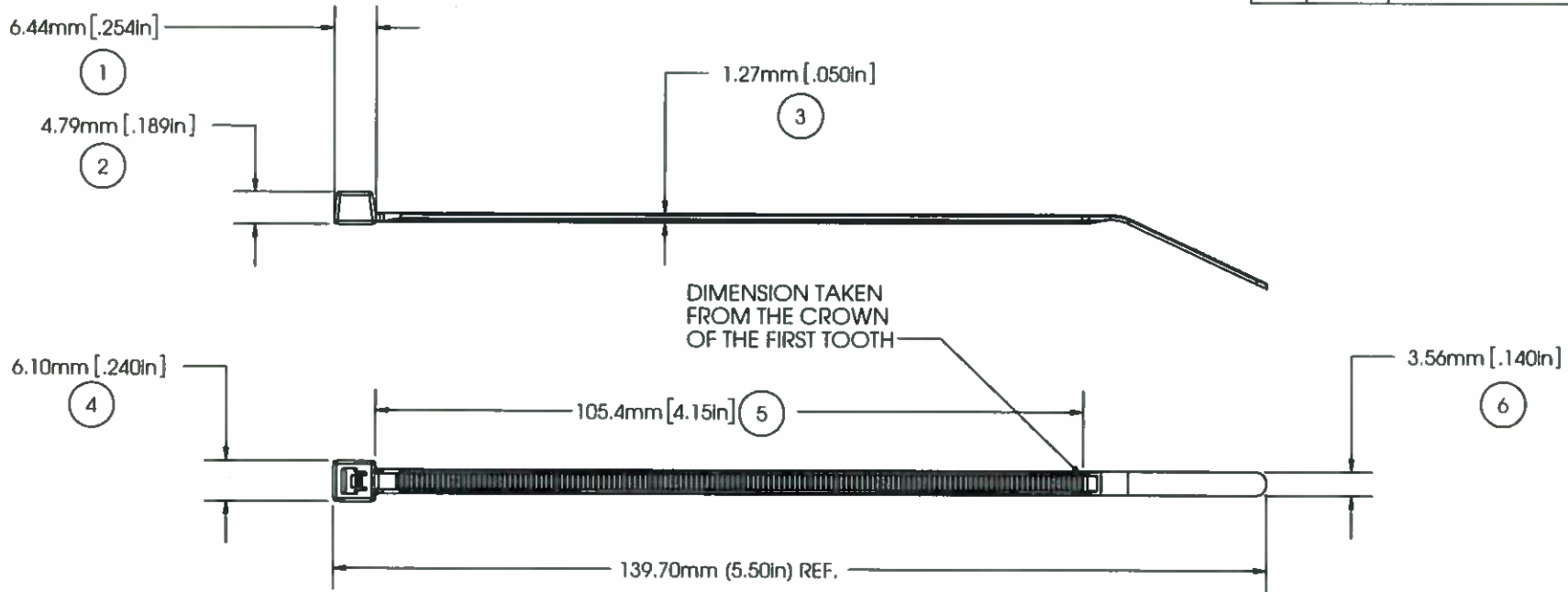

NOTE: THESE CABLE TIES ARE PLENUM RATED AND HAVE A FLAMMABILITY RATING OF V-2



LOOP TENSILE STRENGTH: 40 LBF / 180N MIN. PER AS-23190	APPROVALS: ENG. APPR. <i>LQ. OMD 9/12/14</i> Q.A. APPR. <i>J. Boyle 9/12/14</i>	MATERIAL NYLON 6/6, HEAT STABILIZED	DESCRIPTION 5.5" CABLE TIE, INTERMED.
OPERATING TEMPERATURE: -40°F (-40°C) TO 220°F (105°C)			
MIN. INSTALLATION TEMP.: 32°F (0°C)	SPECIFIED TOLERANCES ARE: .XX ± .03 IN. .X ± .7 MM .XXX ± .010 IN. .XX ± .25 MM ANGULAR: ± 2°	COLOR BLACK	STOCK NO. 08400-0
WEIGHT: 0.025 OZ./0.70 GRAMS			REV. R
BUNDLE DIAMETER: Ø 1.6MM TO Ø 31.8MM			
TOOL: 12001 - HAND INSTALL. TOOL 12500 - PNUM. INSTALL. TOOL			
TOOL TENSION SETTING: 3-5			
PACKAGING: 1000/BAG, 5000/CASE			



AVERY DENNISON

FASTENER DIVISION
FITCHBURG, MA 01420 U.S.A.
TEL. 1-800-225-5913
FAX. 978-353-8157

5

4

3

2

1

AVERY DENNISON MARKETING SPECIFICATION

THE SUBJECT MATTER DISCLOSED HEREIN EMBODIES PROPRIETARY INFORMATION WHICH IS THE CONFIDENTIAL PROPERTY OF THE AVERY DENNISON CO. NONE OF WHICH SHALL BE COPIED, REPRODUCED, DISCLOSED TO OTHERS, PUBLISHED OR USED IN WHOLE OR IN PART, FOR ANY PURPOSE OTHER THAN THAT FOR WHICH IT IS BEING MADE AVAILABLE WITHOUT THE EXPRESS ADVANCE WRITTEN PERMISSION OF A DULY AUTHORIZED AGENT OF THE COMPANY. THIS DOCUMENT IS THE PROPERTY OF THE AVERY DENNISON CO. AND IS TO BE RETURNED TO THE COMPANY ON DEMAND.

HISTORY

REV.	DATE	DESCRIPTION
Q	09.24.13	UPDATE BALLOON 5; ADDED UNITS
R	09.18.14	ADDED OPER. TEMP, UL LOGO ADDED NOTE: CHG DIM 1 TO BE TAKEN FROM THE BOTTOM OF HEAD; ADDED NOTE TO DIM 5, DIMENSION TAKEN FROM CROWN OF THE FIRST TOOTH.

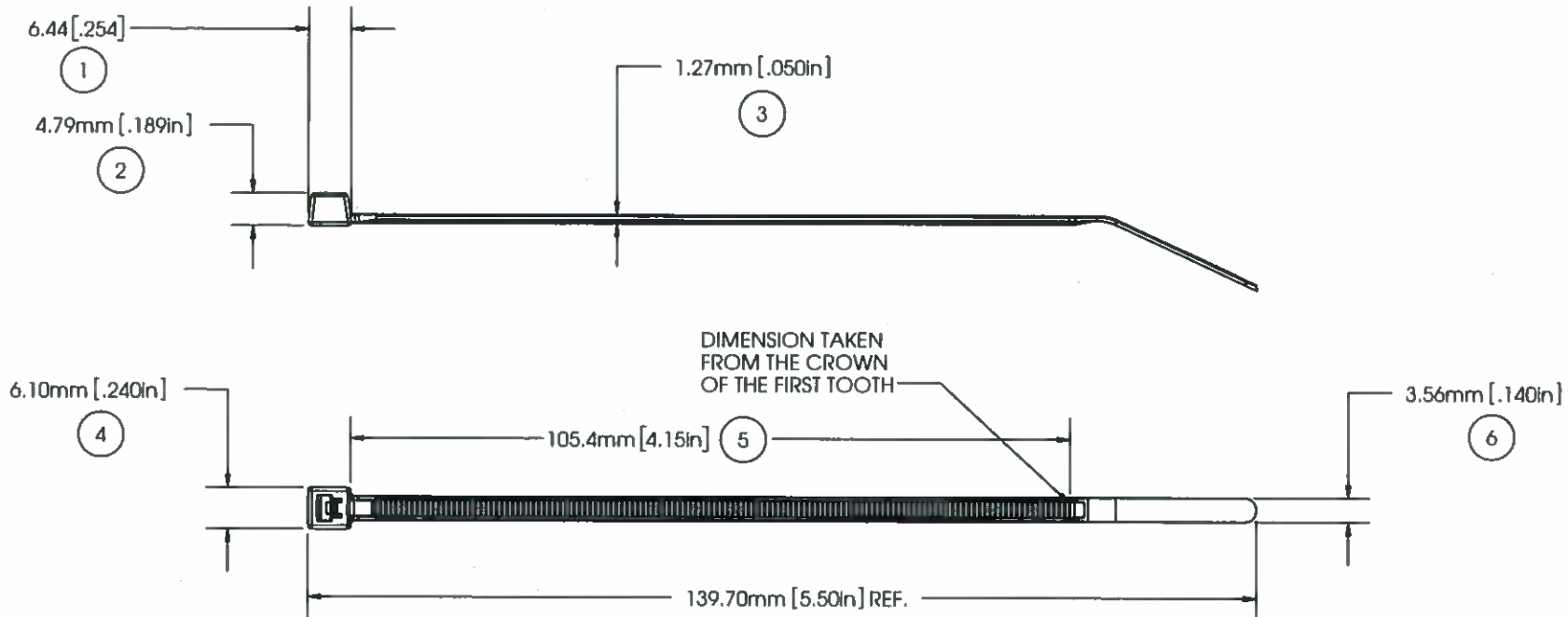

DIMENSION TAKEN FROM THE CROWN OF THE FIRST TOOTH

NOTE: THESE CABLE TIES ARE UV RESISTANT AND HAVE A FLAMMABILITY RATING OF V-2



LISTED
POSITIONING DEVICE
E57800
TYPE 21

MILITARY STANDARD:	MS-3367-5-0
LOOP TENSILE STRENGTH:	40 LBF / 180N MIN. PER AS-23190
OPERATING TEMP:	-40°F(-40°C) TO 176°F(80°C)
MIN. INSTALLATION TEMP:	32°F(0°C)
WEIGHT:	0.025 OZ./0.70 GRAMS
BUNDLE DIAMETER:	Ø 1.6MM TO Ø 31.8MM
TOOL:	12001 - HAND INSTALLATION TOOL 12500 - PNUEM. INSTALLATION TOOL
TOOL TENSION SETTING:	3-5
PACKAGING:	1000/BAG, 5000/CASE

APPROVALS: ENG. APPR. *[Signature]* 9/18/14
Q.A. APPR. *[Signature]* 9/18/14



FASTENER DIVISION
FITCHBURG, MA 01420 U.S.A.
TEL. 1-800-225-5913
FAX. 978-353-8157

SPECIFIED TOLERANCES ARE:		MATERIAL	DESCRIPTION	
.XX ± .03 IN.	.X ± .7 MM	NYLON 6/6, WEATHER RESISTANT	5.5" CABLE TIE, INTERMED.	
.XXX ± .010 IN.	.XX ± .25 MM	COLOR	STOCK NO.	REV.
ANGULAR: ± 2°		BLACK	08431-0	R

5

4

3

2

1