



User Manual

Thank you very much for selecting Menics products. To ensure proper operation, please read this instruction manual thoroughly before attempting to use the system. Also, when undertaking maintenance, inspection or repair work, be sure to refer to this manual.

TO OPERATE THIS PRODUCT SAFELY, PLEASE OBSERVE THE FOLLOWING

NOTES TO BE OBSERVED FOR SAFE OPERATION

Note to be followed to prevent any damage to the user and other personnel or to assets are as follows.

The indications for warning are divided into the following classes according to the degree of danger or damage incurred when the warning is not taken into consideration and the product is not correctly used.

Warning This symbol marks important instructions that, if ignored or incorrectly followed, could conceivably lead to death or serious injury.

Caution This symbol marks important instructions that, if ignored or incorrectly followed, could conceivably lead to injury or property damage.

Warning

Follow wiring diagram completely. If wiring is mistaken, an internal circuit will be damaged and it will become the cause of a fire. Do not use this product without lens or head cover with cracked lens. It may cause electric shock. Make sure power is turned off to avoid electric shock, when you repair this product. Make sure power is turned off and the lamp is cool before you repair anything to avoid electric shock or burning yourself. Make sure power is turned off when checking or changing a fuse to prevent danger of electric shock. Turn off the power supply before making wiring connections. Neglecting may cause an electric shock. All loose ends of wires left unconnected upon the completion of wiring must be insulated individually, or they may cause equipment problems, short circuits or electric shock. When mounting the unit outdoors or in a place where water may splash on it, avoid inverted or sideways mount. If water seeps into the unit through the drain hole on the bottom of the case, and collects inside, it may cause an electric shock or short circuit. Be sure to waterproof the uncoated part of power supply line and signal line in case this product is used in the rain or water exposing environment. Water immersion of the product may result in malfunction or electric shock. Residual high voltage may cause electric shock! Please wait 1 minute or more before you change lamp.

Caution

Use only specified operating voltage range. Excess voltage hastens degradation. Make sure to set fuse in a power supply side, please connect a fuse. To clean lens, head cover, and body, wipe with water or glass cleaner soaked soft cloth. Do not use thinner or benzine, gasoline, oil as these cause color change or deform the surface. Make sure not to use any other lamps except ones described in specifications.



1. Ordering Information

MS86S - S 0 0 - R

① ② ③

1. Option

| | |
|----------|-----------------------|
| S | Internal molding type |
| N | Standard (not molded) |

2. Power supply

| | |
|-----------|---------------|
| 00 | 12 ~ 24VAC/DC |
| 10 | 110VAC |
| 20 | 220VAC |

3. Lens color

| | |
|----------|--------|
| R | Red |
| Y | Yellow |
| G | Green |
| B | Blue |
| C | Clear |

[Reference 1]
The power specifications for type of molding 00: 12 ~ 24V AC / DC applies only to products.

2. Part name

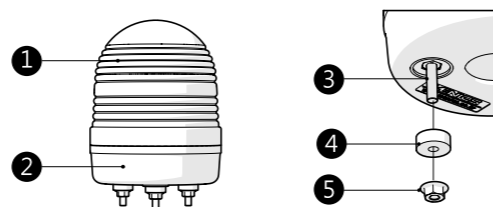

| No | Part name | Material |
|----|-------------------|-----------|
| 1 | Lens cap | PC resin |
| 2 | Base Body | ABS resin |
| 3 | Fastening screw | SUS M4X20 |
| 4 | Dustproof rubber | NBR |
| 5 | Flange fixing nut | SUS M4 |

Bulbs

| Supplier No. | MS86S-LAMP-02 | MS86S-LAMP-10 |
|--------------|---|---|
| | <p>Description. Xenon Lamp I- Type, 3W 12~24V Lamp life: 1,000,000 Frequency. (2,000 hours)</p> | <p>Description. Xenon Lamp U- Type, 6W AC110V Lamp life: 1,000,000 Frequency. (2,000 hours)</p> |

3. Specifications

| | |
|-----------------------------|--|
| Dimension | 86mm |
| Light source | Xenon strobe lamp |
| Power Supply | 12 ~24VAC/DC 110VAC , 220VAC (AC 50/60Hz) |
| Mounting direction | Body direct mount , L-shaped bracket |
| Lens color | Red, Yellow, Green, Blue, Clear (Material: PC resin) |
| Flash rate | Approx. 80time/minute (±10%) |
| Current Consumption | 12 ~ 24V: 0.08~0.15A 110V: 0.07A 220V: 0.03A |
| Vibration | 0.75mm at 10~55Hz |
| Ambient Temperature | -20 ~ 40°C |
| Storage ambient temperature | -20 ~ 70°C |
| Ambient Humidity | 45 ~ 85% RH |
| Protection structure | IP65 |
| Approval | UL, RoHS |
| Wire Size | UL2464/22AWG x 2C |
| Weight | 300g - Molding type , 200g - Standard |

4. Dimensions (unit: mm)

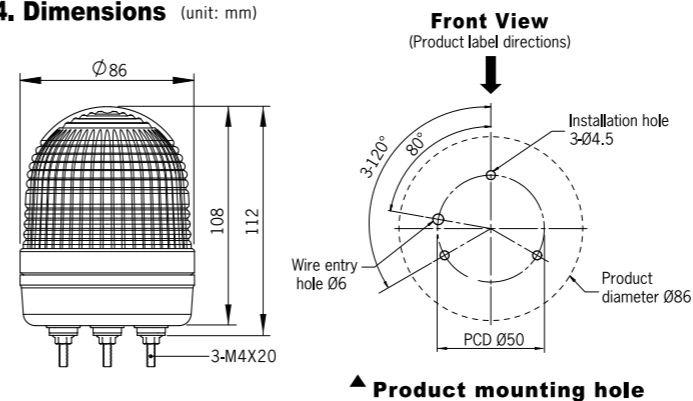

5. Orientation of mounted unit

- When the installation of this product requires the construction, please ask to specialist. Electric shock, fire and fall may occur.
- When installing the unit in a high place, choose the place where a foothold can be secured for case in repairs.

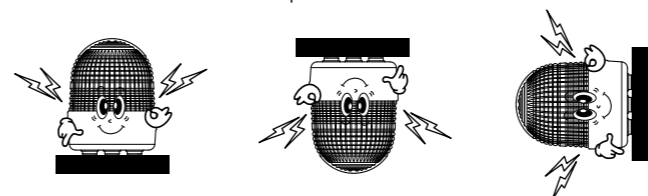

6. Wiring Connection

- Before wiring, make sure the power is not supplied to the unit in order to avoid the possibility of electric shock.
- Be careful not to make a mistake during the wiring of this unit. Otherwise an internal circuit will be damaged and may start a fire.

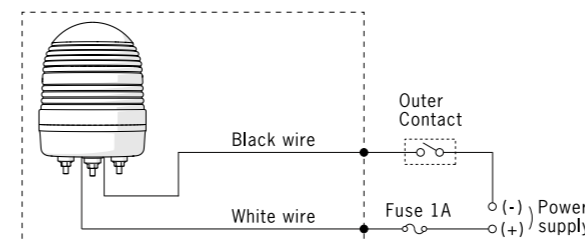

7. How to change xenon lamp

Warning Residual high voltage may cause electric shock! Please wait 1 minute or more over before you change lamp.

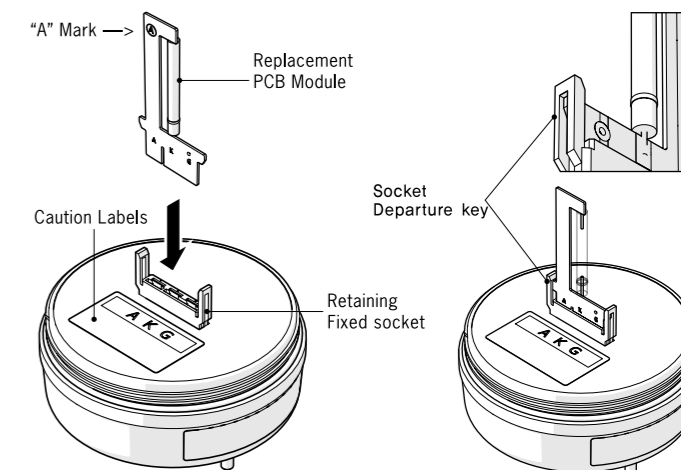

The new lamp should be inserted firmly to match the same signal A K G (or A G K) mark. Printed "A" in circuit and label.

Warning - If you insert reverse direction, the lamp can not operate.
- Insert the lamp circuit board correctly. not to inclined.

8. Mounting Accessories

Wall Mount Brackets

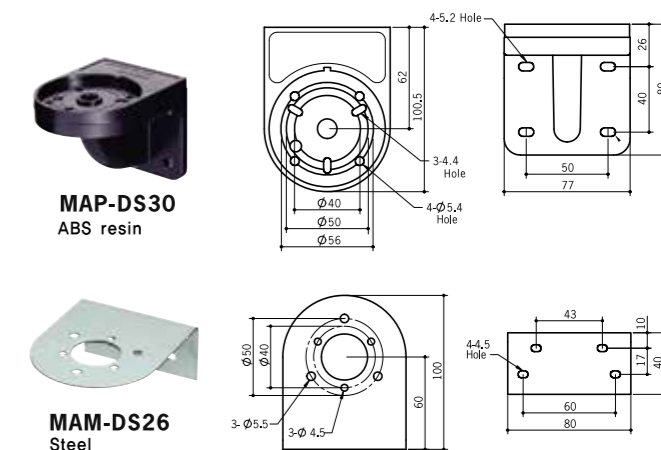

* Specifications are subject to change without notice.