

Shaft Type Ø68mm Incremental Rotary Encoder

■ Features

- Ø68mm, shaft diameter: Ø15mm
- High speed response frequency: 180kHz
- Radial connector type
- Suitable for tooling machinery
- Protection structure IP65 (IEC standard)
(tentative water-proof/oil)
- High shaft loading capabilities (allowable load weight is 10kgf)

⚠ Please read "Safety Considerations" in operation manual before using.

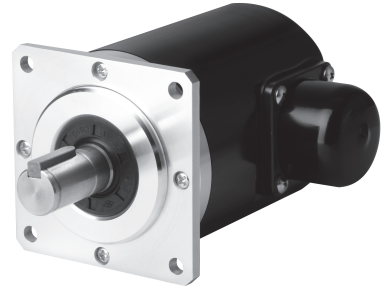

■ Ordering Information

E68S	15	1024	6	L	5
Series	Shaft diameter	Pulses/revolution	Output phase	Control output	Power supply
Ø68mm, shaft type	Ø15mm	500, 600, 1024	6: A, \bar{A} , B, \bar{B} , Z, \bar{Z}	L: Line driver output	5VDC \pm 5%

※Connector standard: MS3102A20-29P

■ Specifications

Item	Shaft Type Ø68mm Incremental Rotary Encoder	
Resolution (PPR) ^{※1}	500, 600, 1024	
Electrical specification	Output phase	A, \bar{A} , B, \bar{B} , Z, \bar{Z} phase
	Phase difference of output	Phase difference between A and B: $\frac{T}{4} \pm \frac{T}{8}$ (T=1 cycle of A phase)
	Control output	• [Low] - Load current: max. 20mA, residual voltage: max. 0.5VDC= • [High] - Load current: max. -20mA, output voltage: min. 2.5VDC= =
	Response time (rise/fall)	Max. 0.5 μ s (cable: 1m, I sink = 20mA)
	Power supply	5VDC= \pm 5% (ripple P-P: max. 5%)
	Max. response frequency	180kHz
	Current consumption	Max. 50mA (disconnection of the load)
	Insulation resistance	Over 100M Ω (at 500VDC megger) (between all terminals and case)
	Dielectric strength	750VAC 50/60Hz for 1 minute (between all terminals and case)
	Connection	Radial connector type (MS3102A20-29P)
Mechanical specification	Starting torque	Max. 1.5kgf·cm (0.15N·m)
	Shaft loading	Radial: max. 20kgf, Thrust: max. 10kgf
	Max. allowable revolution ^{※2}	6,500rpm
Vibration	1.5mm amplitude at frequency of 10 to 55Hz (for 1 min) in each X, Y, Z direction for 2 hours	
Shock	Approx. max. 50G	
Environment	Ambient temperature	-10 to 70°C, storage: -25 to 85°C
	Ambient humidity	35 to 85%RH, storage: 35 to 90%RH
Protection structure	IP65 (IEC standard)	
Unit weight	Approx. 550g	

※1: Not indicated resolutions are available customizable.

※2: Make sure that max. response revolution should be lower than or equal to max. allowable revolution when selecting the resolution.

$$[\text{Max. response revolution (rpm)}] = \frac{\text{Max. response frequency}}{\text{Resolution}} \times 60 \text{ sec}$$

※Environment resistance is rated at no freezing or condensation.

(A)	Photoelectric Sensors
(B)	Fiber Optic Sensors
(C)	Door/Area Sensors
(D)	Proximity Sensors
(E)	Pressure Sensors
(F)	Rotary Encoders
(G)	Connectors/ Connector Cables/ Sensor Distribution Boxes/Sockets
(H)	Temperature Controllers
(I)	SSRs / Power Controllers
(J)	Counters
(K)	Timers
(L)	Panel Meters
(M)	Tacho / Speed / Pulse Meters
(N)	Display Units
(O)	Sensor Controllers
(P)	Switching Mode Power Supplies
(Q)	Stepper Motors & Drivers & Controllers
(R)	Graphic/ Logic Panels
(S)	Field Network Devices
(T)	Software

E68S Series

Control Output Diagram

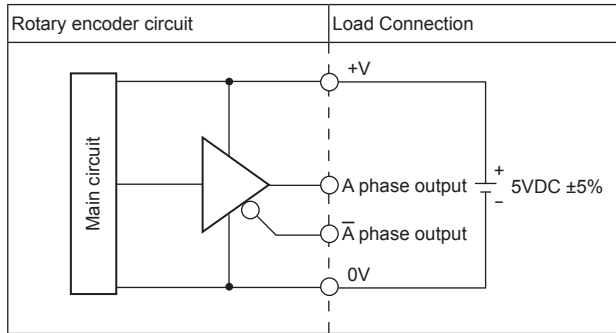

※All output circuits of A, \bar{A} , B, \bar{B} , Z, \bar{Z} phase are same.

Output Waveform

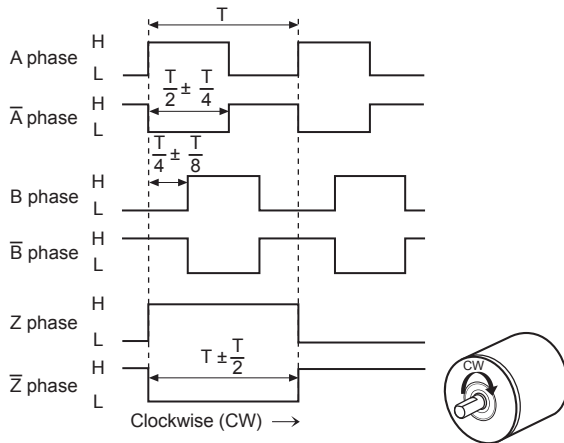

Connections

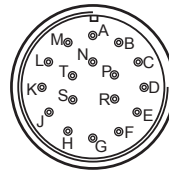

Pin No.	Connection
A	A phase
B	Z phase
C	B phase
D, F, G, J, L, S	N-C
E, H	5VDC
K, M	0V
N	A phase
P	\bar{Z} phase
R	\bar{B} phase
T	Shield (F.G.)

※N-C: Not Connected.

※E and H terminals, K and M terminals are connected internally.

Dimensions

(unit: mm)

