

Autonics

ROTARY ENCODER(INCREMENTAL TYPE) E60H SERIES

M A N U A L



Thank you very much for selecting Autonics products.
For your safety, please read the following before using.

Caution for your safety

※Please keep these instructions and review them before using this unit.

※Please observe the cautions that follow;

Warning Serious injury may result if instructions are not followed.

Caution Product may be damaged, or injury may result if instructions are not followed.

※The following is an explanation of the symbols used in the operation manual.

Caution: Injury or danger may occur under special conditions.

Warning

1. When use this unit for controlling highly effective equipment to human or properties.

(Medical instrument, Vehicles, Train, Airplane, combustion apparatus, entertainment etc.), it requires installing a fail safety device.

It may cause serious human injury or a fire, property.

Caution

1. Do not drop water or oil on this unit.

It may cause damage or miscontrol due to malfunction.

2. Please observe voltage rating.

It may shorten the life cycle or damage to the product.

3. Please check the polarity of power and wrong wiring.

It may result in damage to this unit.

4. Do not short circuit the load.

It may result in damage to this unit.

Ordering information

E60H	20	8192	3	N	24
------	----	------	---	---	----

Series	Shaft inside diameter	Pulse/1Revolution	Output phase	Output type	Power supply	Cable
Diameter ø 60mm, Hollow shaft type	ø 20mm	100, 1024 5000, 8192	3 : A, B, Z 6 : A, \bar{A} , B, \bar{B} , Z, \bar{Z}	T : Totem pole output N : NPN open collector output V : Voltage output L : Line driver output	5 : 5VDC \pm 5% 24 : 12-24VDC \pm 5%	No mark:Normal type* C:Cable connector type

※Cable length : 250mm

Control output diagram

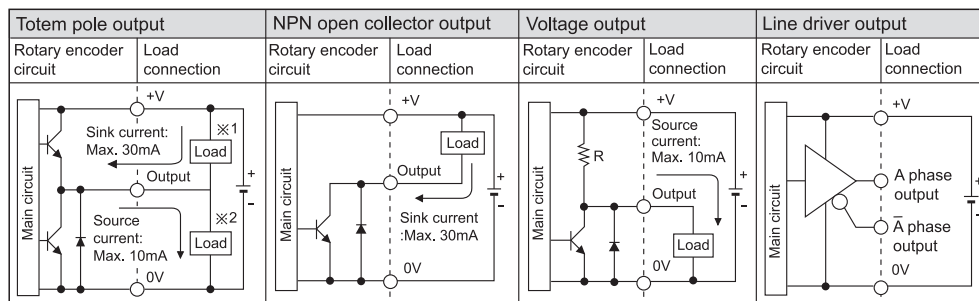

- The output circuit of A, B, Z phase are the same. (Line driver output is A, \bar{A} , B, \bar{B} , Z, \bar{Z})

- Totem pole output can be used for NPN open collector output type(※1) or voltage output type(※2).

※The above specifications are subject to change and some models may be discontinued without notice.

Specifications

Item	Diameter ø 60mm hollow shaft type Incremental Rotary encoder		
Model	E60H20-3-T- <input type="checkbox"/> E60H20-3-N- <input type="checkbox"/>	E60H20-3-V- <input type="checkbox"/> E60H20-6-L- <input type="checkbox"/>	
Revolution(P/R)※1	100, 1024, 5000, 8192		
Output phase	A, B, Z phase (Line driver output A, \bar{A} , B, \bar{B} , Z, \bar{Z} phase)		
Phase difference of output	Phase difference between A and B : $\frac{T}{4} \pm \frac{T}{8}$ (T=1 cycle of A phase)		
Electrical specification	Totem pole output	• Low - Load current:Max. 30mA, Residual voltage:Max. 0.4VDC • High - Load current:Max. 10mA, Output voltage(power supply 5VDC):Min.(power supply-2.0)VDC, Output voltage(power supply 12-24VDC):Min.(power supply-3.0)VDC	
	NPN open collector output	Load current : Max. 30mA, Residual voltage : Max. 0.4VDC	
	Voltage output	Load current : Max. 10mA, Residual voltage : Max. 0.4VDC	
	Line driver output	• Low - Load current : Max. 20mA, Residual : Max. 0.5VDC • High - Load current : Max. 20mA, Output voltage(power supply 5VDC):Min. 2.5VDC, Output voltage(ower supply 12-24VDC):Min.(power supply-3.0)VDC	
Mechanical specification	Totem pole output	• Measuring condition - Cable length : 2m, I sink=Max. 20mA	
	NPN open collector output		Max. 1μs
	Voltage output		
	Line driver output		Max. 0.5μs
Max. Response frequency	300kHz		
Power supply	• 5VDC \pm 5%(ripple P-P:Max. 5%) • 12-24VDC \pm 5%(ripple P-P:Max. 5%)		
Current consumption	Max. 80mA(disconnection of the load), Line driver output:Max. 50mA(disconnection of the load)		
Insulation resistance	Min. 100MΩ (at 500VDC between all terminals and case)		
Dielectric strength	750VAC 50/60Hz for 1 minute(between all terminals and case)		
Connection	Cable type, 250mm cable connector type		
Starting torque	Max. 150gf-cm(0.015N-m)		
Moment of inertia	Max. 110g-cm ² (11× 10 ⁻⁶ kg-m ²)		
Shaft loading	Radial : 5kgf, Thrust : 2.5kgf		
Max. allowable revolution※2	6000rpm		
Vibration	1.5mm amplitude or 300m/s ² at frequency of 10 to 55Hz in each of X, Y, Z directions for 2 hours		
Shock	Max. 100G		
Ambient temperature	-10 to 70°C, Storage: -25 to 85°C		
Ambient humidity	35 to 85%RH, Storage: 35 to 90%RH		
Protection	IP50(IEC standard)		
Cable	ø 5, 5-wire, Length: 2m, Shield cable(Line driver output : ø 5, 8-wire) (AWG24, Core diameter: 0.08mm, Number of cores: 40, Insulator out diameter: ø 1)		
Accessory	Bracket 2EA		
Weight※3	Approx. 397g(approx. 330g)		

※1: Not indicated type is customizable.

※2: Max. allowable revolution \geq Max. response revolution

$$[\text{Max. response revolution(rpm)}] = \frac{\text{Max. response frequency}}{\text{Resolution}} \times 60 \text{ sec}$$

Please select the resolution to make lower max. revolution than max. allowable revolution.

※3: The weight with packaging and the weight in parentheses is only unit weight.

※Environment resistance is rated at no freezing or condensation.

Dimension

Normal type

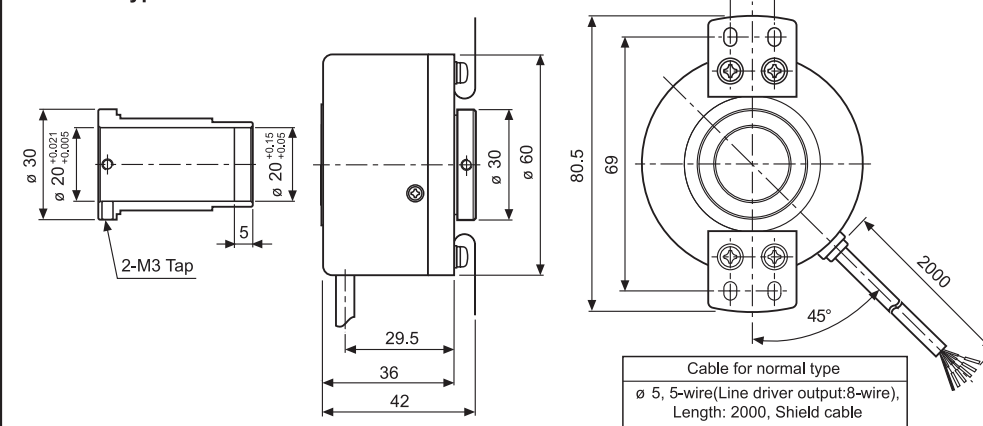

Cable connector type

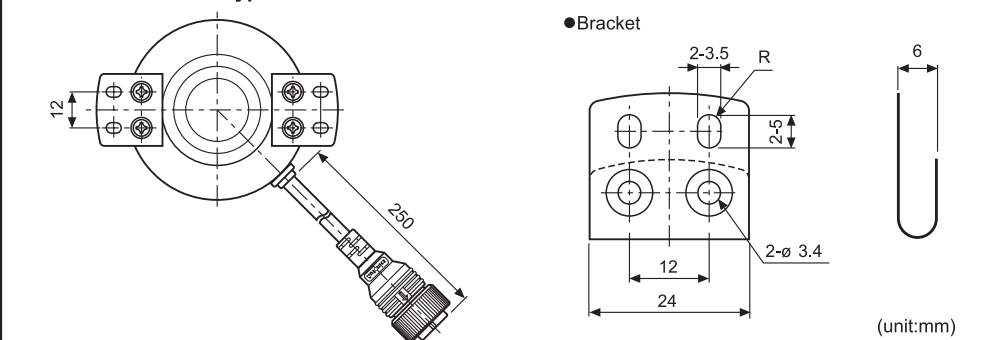

Connections

Normal type

• Totem pole output / NPN open collector output / Voltage output

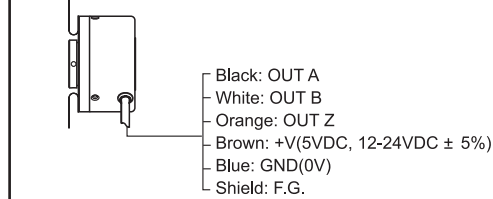

※Unused wires must be insulated.

※The metal case and shield cable of encoder should be grounded(F.G.).

Line driver output

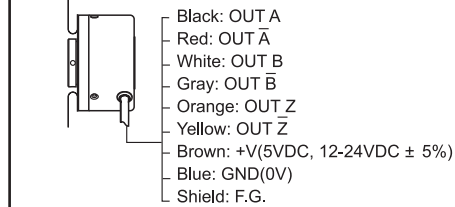

Cable connector type

• Totem pole output / NPN open collector output / Voltage output



Totem pole output NPN open collector output Voltage output			Line driver output		
Pin No.	Function	Cable color	Pin No.	Function	Cable color
①	OUT A	Black	①	OUT A	Black
②	OUT B	White	②	OUT \bar{A}	Red
③	OUT Z	Orange	③	+V	Brown
④	+V	Brown	④	GND	Blue
⑤	GND	Blue	⑤	OUT B	White
⑥	F.G.	Shield	⑥	OUT \bar{B}	Gray
			⑦	OUT Z	Orange
			⑧	OUT \bar{Z}	Yellow
			⑨	F.G.	Shield

※F.G.(Field Ground) : It should be grounded separately.

Output waveform

• Totem pole output / NPN open collector output / Voltage output

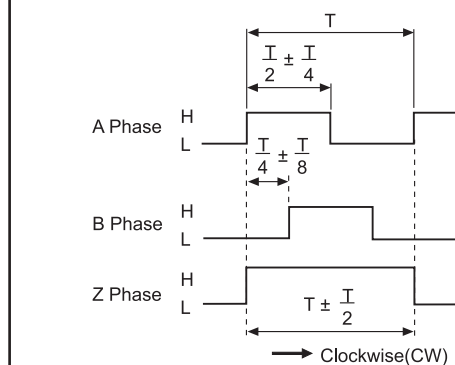

※Clockwise(CW) : Right turn as from the shaft

• Line driver output

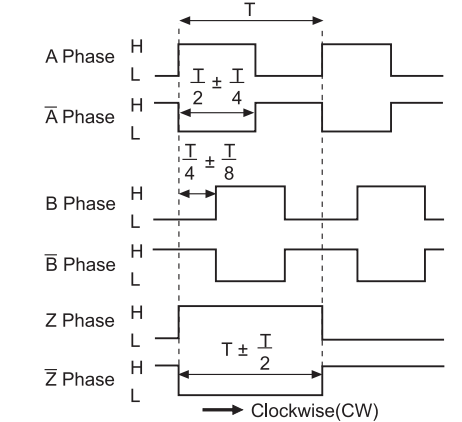

Caution for using

1. Installation

- This unit is consisted of precision components. Therefore please treat this product carefully.
- For the installation, please check the assembly dimension of counterpart, then try not to occur the offset between shaft hole and the object. It might shorten the life cycle of the product.
- Do not put strong impact when insert coupling into shaft.

2. For using

- Please connect shield wire to F.G terminal. (Encoder+Motor+Panel F.G.)
- Do not connect and cut circuit off during power on. It may result in damage to this unit.
- When the power source is a Switching Power, please install the surge absorber in power line and wire should be short in order not to be influenced by noise.

3. Environment

- Please do not use this unit with below environment, it results in malfunction.
- Place where this unit or component may be damaged by strong vibration or impact.
 - Place where there are lots of flammable or corrosive gases.
 - Place where strong magnet field or electric noise are occurred.
 - Place where is beyond of rating temperature or humidity.
 - Place where strong acids or alkali near by.

4. Vibration and Impact

- When the strong impact loads on this unit, the error pulse may occur as if the slit is revolving.
- Please fix this unit firmly when mount it in order to avoid malfunction by residual vibration.

5. Wire connection

- If use the cable of encoder and high voltage line or power cable in the same conduit, it may cause a malfunction or mechanical trouble. Please wire separately or use separated conduit.
- Please check wire and response frequency when extend wire because of distortion of waveform or residual voltage increment etc by line resistance or capacity between lines.

※It may cause malfunction if above instructions are not followed.

Major products

- Photoelectric sensors
- Fiber optic sensors
- Door sensors
- Door side sensors
- Area sensors
- Proximity sensors
- Pressure sensors
- Rotary encoders
- Connector/Sockets
- Switching mode power supplies
- Control switches/Lamps/Buzzers
- I/O Terminal Blocks & Cables
- Stepper motors/drivers/motion controllers
- Graphic/Logic panels
- Field network devices
- Laser marking system(Fiber, CO₂, Nd:YAG)
- Laser welding/soldering system
- Temperature controllers
- Temperature/Humidity transducers
- SSR/Power controllers
- Counters
- Timers
- Panel meters
- Tachometer/Pulse(Rate) meters
- Display units
- Sensor controllers

Autonics Corporation
http://www.autonics.com

Satisfiable Partner For Factory Automation

■ HEAD QUARTERS:
18, Bansong-ro 513beon-gil, Haeundae-gu, Busan, Korea

■ OVERSEAS SALES:
#402-404, Bucheon Techno Park, 655, Pyeongcheon-ro, Wonmi-gu, Bucheon, Gyeonggi-do, Korea
TEL: 82-32-610-2730 / FAX: 82-32-329-0728
E-mail: sales@autonics.com