

AMPROBE®

HARD AT WORK SINCE 1948.

CT-53

3000 A Flexible 3-Sensor Current Transducer

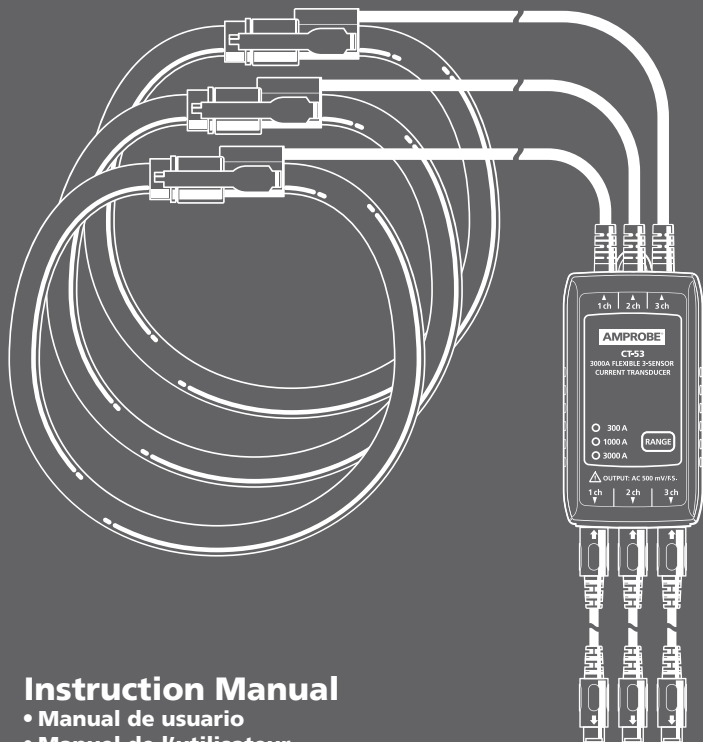

Instruction Manual

- Manual de usuario
- Manuel de l'utilisateur

AMPROBE®

CT-53

**3000 A Flexible 3-Sensor Current
Transducer**

Instruction Manual

English

Limited Warranty and Limitation of Liability

Your Amprobe product will be free from defects in material and workmanship for one year from the date of purchase unless local laws require otherwise. This warranty does not cover fuses, disposable batteries or damage from accident, neglect, misuse, alteration, contamination, or abnormal conditions of operation or handling. Resellers are not authorized to extend any other warranty on the behalf of Amprobe. To obtain service during the warranty period, return the product with proof of purchase to an authorized Amprobe Service Center or to an Amprobe dealer or distributor. See Repair Section for details. THIS WARRANTY IS YOUR ONLY REMEDY. ALL OTHER WARRANTIES - WHETHER EXPRESS, IMPLIED OR STATUTORY - INCLUDING IMPLIED WARRANTIES OF FITNESS FOR A PARTICULAR PURPOSE OR MERCHANTABILITY, ARE HEREBY DISCLAIMED. MANUFACTURER SHALL NOT BE LIABLE FOR ANY SPECIAL, INDIRECT, INCIDENTAL OR CONSEQUENTIAL DAMAGES OR LOSSES, ARISING FROM ANY CAUSE OR THEORY. Since some states or countries do not allow the exclusion or limitation of an implied warranty or of incidental or consequential damages, this limitation of liability may not apply to you.

Repair

All Amprobe returned for warranty or non-warranty repair or for calibration should be accompanied by the following: your name, company's name, address, telephone number, and proof of purchase. Additionally, please include a brief description of the problem or the service requested and include the test leads with the meter. Non-warranty repair or replacement charges should be remitted in the form of a check, a money order, credit card with expiration date, or a purchase order made payable to Amprobe.

In-warranty Repairs and Replacement – All Countries

Please read the warranty statement and check your battery before requesting repair. During the warranty period, any defective test tool can be returned to your Amprobe distributor for an exchange for the same or like product. Please check the "Where to Buy" section on www.Amprobe.com for a list of distributors near you. Additionally, in the United States and Canada, in-warranty repair and replacement units can also be sent to an Amprobe Service Center (see address below).

Non-warranty Repairs and Replacement – United States and Canada

Non-warranty repairs in the United States and Canada should be sent to an Amprobe Service Center. Call Amprobe or inquire at your point of purchase for current repair and replacement rates.

USA:
Amprobe
Everett, WA 98203
Tel: 888-993-5853
Fax: 425-446-6390

Canada:
Amprobe
Mississauga, ON L4Z 1X9
Tel: 905-890-7600
Fax: 905-890-6866

CT-53 3000 A Flexible 3-Sensor Current Transducer

CONTENTS

INTRODUCING THE CT-53	2
SYMBOL.....	4
SAFETY INFORMATION.....	4
MEASUREMENTS.....	5
MAINTENANCE.....	8
SPECIFICATIONS	8

INTRODUCING THE CT-53

The CT-53 Flexible 3-Sensor Current Transducer is an optional accessory that is used to measure current up to 3000A on the Amprobe DM-5 Power Quality Analyzer. The flexible and light weight measuring head is ideal for current measurement on thick and hard to reach conductors without breaking the circuit. The circuit box contains measuring circuits for 3-channel.

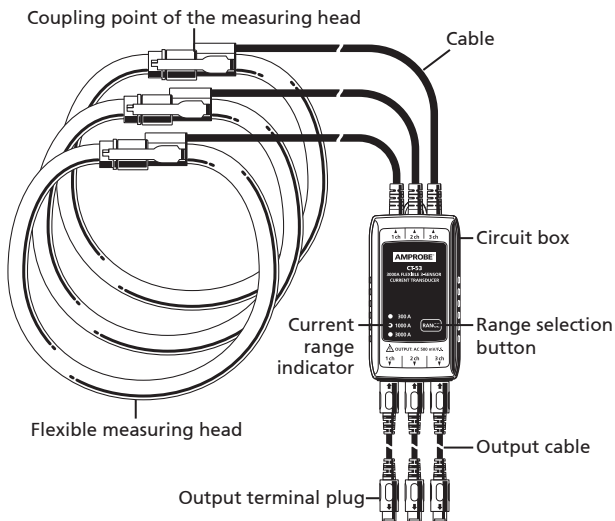





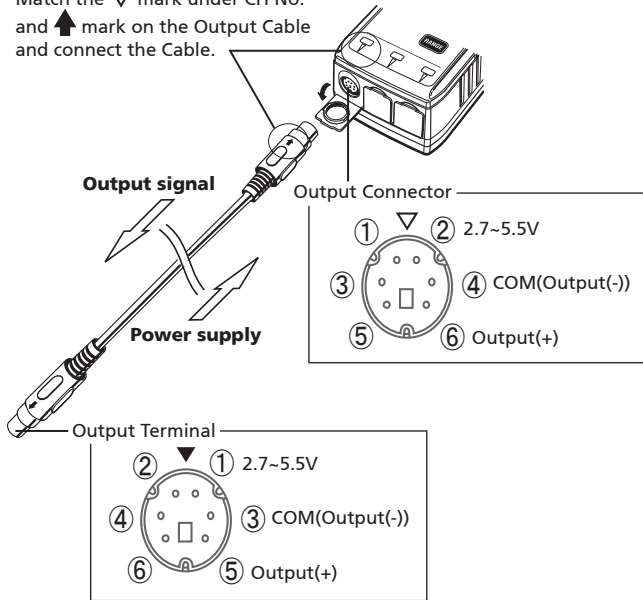



Pins of output terminal

Match the ▽ mark under CH No. and ▲ mark on the Output Cable and connect the Cable.



- Output signal is between pin 3 and 5 of output terminal and between 4 and 6 of output connector.
- The current clamp is powered via pin 1 and 3 (2.7 to 5.5 V, 200 mA) of output terminal and pin 2 and 4 of output connector.
- Resistance between 3 and 6 of Output terminal and between 4 and 5 of Output connector is as stated below:
300A range: 910 k Ω
1000A range: 360 k Ω
3000A range: 510 k Ω
(Resistance cannot be measured while the instrument is powered off.)
- Connecting terminal on DM-5 is symmetrical to above pin configurations.

SYMBOLS

	Do not apply around, or remove from, HAZARDOUS LIVE conductors.
	Caution! Risk of electric shock.
	Caution! Refer to the explanation in this manual.
	Alternating current (AC).
	The equipment is protected by double insulation or reinforced insulation.
	Underwriters Laboratories (applies to Canada and U.S.A.)
	Complies with European directives.
	Cumple las normas australianas pertinentes
	Do not dispose this product as unsorted municipal waste. Contact a qualified recycler.

SAFETY INFORMATION

The current transducer complies with:

- UL/IEC 61010-1, Measurement CAT III 600 V, Pollution degree 2
- IEC 61010-2-030
- IEC 61010-2-032
- EMC IEC 61326-1

CENELEC DIRECTIVES

The instruments conform to CENELEC Low-voltage directive 2006/95/EC and Electromagnetic compatibility directive 2004/108/EC.

Warning: Read before Using

To ensure safe operation and service of the current transducer, follow these instructions:

- Read the operating instructions before use and follow all safety instructions.
- Use the current transducer only as specified in the operating instructions; otherwise the current transducer's safety features may be compromised.
- Adhere to local and national safety codes. Individual protective equipment must be used to prevent shock and arc blast injury where hazardous live conductors are exposed.

- Before each use, inspect the current transducer and its latching system for any damage. Pay particular attention to the insulation surrounding the flexible measuring head. Look for cracks or missing portions of the current transducer housing or output cable insulation. Also look for loose or weakened components.
- Do not use a current transducer that is cracked, damaged, or has a defective cable.
- Never use the current transducer on a circuit with voltages higher than 600 V CAT III.
 - CAT III equipment is designed to protect against transients in equipment in fixed equipment installations, such as distribution panels, feeders and short branch circuits, and lighting systems in large buildings.
- De-energize the installation on which current will be measured or adopt safe operating procedures during application and removal of the current transducer.
- Use extreme caution when working around bare conductors or bus bars.
- Do not use the current transducer to measure bare conductors carrying a voltage from 30V up to 600V unless you are wearing protective clothing suitable for high-voltage work. Contact with the conductor could result in electric shock. Always use appropriate equipment for personal protection.
- Use caution when working with voltages above 60 V dc, 30 V ac rms or 42 V ac peak. Such voltages pose a shock hazard.
- Never apply to current exceeding the measuring range.
- Ensure that no foreign object obstructs the latching mechanism.
- Do not operate the current transducer around explosive gas, vapor, or dust.
- Do not step on or pinch the cord. It may damage the insulation.
- Do not expose the current transducer to direct sunlight, high temperatures/humidity or dew. It may cause deformation or insulation degradation.

MEASUREMENTS

Warning

To avoid electric shock or personal injury:

- Do not use the current transducer on a circuit with voltages higher than 600 V CAT III.
- De-energize the installation on which current will be measured or adopt safe operating procedures during application and removal of the current transducer.
- Disconnect CT-53 from DM-5 by removing CT-53 output terminal plug. Do not pull CT-53 output cable.

To measure AC current:

1. Connect CT-53 output terminals to DM-5 current input terminals (A1, A2, A3). Observe the arrow marks for correct connection.

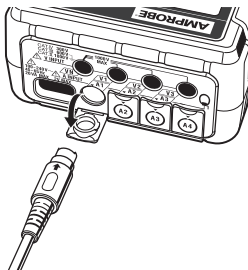

2. Power on DM-5 (unit auto-detects the current transducer connected).
3. Unlock the flexible measuring head according to the followings:

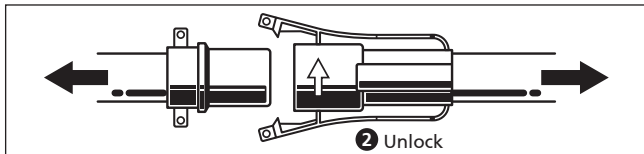
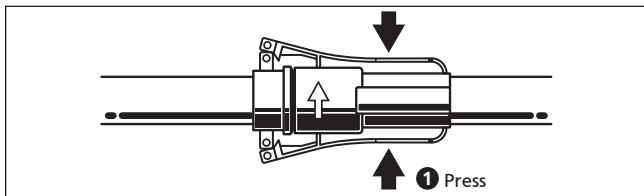
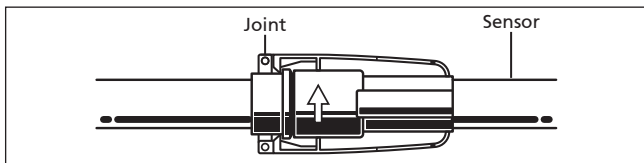

4. Connect the flexible measuring head around the conductor.
5. Make sure the arrow marked on the measuring head coupling points towards the current flowing direction of the conductor, and position the conductor under test as shown below.

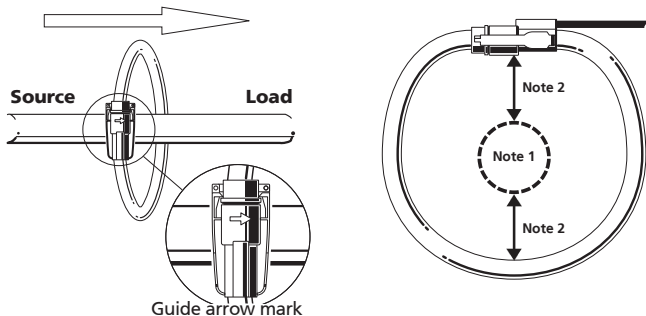

Note 1: Reference measurement position of the conductor. Maximum coupling diameter: 20 mm for published accuracy.

Note 2: Keep minimum 65 mm to ensure published accuracy.

6. Ensure the coupling point of the flexible measuring head is firmly locked.
7. Press RANGE button to select any desirable range (300A/ 1000A/ 3000A). When powering off the instrument once and powering on again, the range will be the same one selected prior to powering off the instrument.

⚠ Caution

- The coupling point may disconnect if excessive pulling force is applied.
- Clamp onto one conductor only. Measurement cannot be made when clamping single-phase (2-wire) or three-phase (3-wire) at the same time.

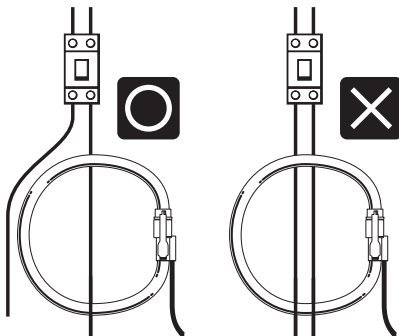

MAINTENANCE

Before each use, inspect the flexible current transducer and its latching system for any damage for continued safety. Pay particular attention to the insulation surrounding the flexible measuring head.



The flexible current transducer and its latching system require no special care. Ensure that no foreign object obstructs the latching mechanism. Clean the CT-53 with a damp cloth and a mild detergent. Do not use abrasives, solvents, or alcohol.

If CT-53 does not perform properly, use the following steps to help isolate the problem:

- Inspect the coupling system for any damage. If a foreign material is present, the coupling system will not close properly and errors will result.
- Inspect the cables between the flexible measuring head and CT-53 circuit box. Also inspect between the CT-53 circuit box and DM-5 for any damage.
- Check the selected RANGE on the circuit box and ensure that the RANGE indicator is ON.
- Verify the transducer setting on DM-5 is correct.

SPECIFICATIONS

Current range	300 A / 1000 A / 3000 A AC rms
Output voltage	300 A range: 500 mVac / 300 Aac (1.67 mV / A) 1000 A range: 500 mVac / 1000 Aac (0.5 mV / A) 3000 A range: 500 mVac / 3000 Aac (0.167 mV / A)
Measuring range	300 A range: 30 A to 300 A (424 Apeak) 1000 A range: 100 A to 1000 A (1414 Apeak) 3000 A range: 300 A to 3000 A (4243 Apeak)
Conductor size	Ø20 mm (0.787 in) maximum for published accuracy
Accuracy (sine wave)*	±1.0% (45 Hz to 65 Hz)
Phase characteristics	Within ±1° 300 A range: 30 A to 300 A (45 Hz to 65 Hz) 1000 A range: 100 A to 1000 A (45 Hz to 65 Hz) 3000 A range: 300 A to 3000 A (45 Hz to 65 Hz)

Working voltage	600 Vac rms
Max allowed input	3600 Aac continuous (45 Hz to 65 Hz)
Possible measurable conductor size	Max. Ø150 mm (5.9 in) (accuracy error not specified)
Head circumference	550 mm (21.65 in)
Head cable diameter	14.3 mm (0.56 in)
Cable length (head to electronics)	Approx. 2 m (6.56 ft)
Cable length (output cable)	Approx. 1 m (3.28 ft)
Output terminal	Mini-DIN-6 connector
Output impedance	100 Ω or less
Current consumption (at power supply 5 V)	15 mA (typical)
Operating temperature and humidity	32 °F to 122 °F (0 °C to 50 °C), ≤85 %RH (no condensation) Guaranteed accuracy at 73 °F ± 9 °F (23 °C ± 5 °C), ≤85 %RH (no condensation)
Storage temperature and humidity	-4 to 140 °F (-20 °C to 60 °C), ≤ 85 % RH (no condensation)
Operating altitude	0 to 2000 m
EMC	EN 61326-1
Safety compliance	UL/IEC 61010-1, IEC 61010-2-030, IEC 61010-2-032 Measurement CAT III 600 V, Pollution degree 2
Certification	  
Weight	Approx. 950 g (2.1 lbs)

* See Note 1 and Note 2 on page 7 for reference measurement position of the conductor.

Visit www.Amprobe.com for

- **Catalog**
- **Application notes**
- **Product specifications**
- **User manuals**

Amprobe®

www.Amprobe.com

info@amprobe.com

Everett, WA 98203

Tel: 877-AMPROBE (267-7623)



Please
Recycle