

# Agilent 86082A Wavelength Domain Component Analyzer

Real-time measurements

An integrated system, the 86082A brings together the strengths of an optical spectrum analyzer and a tunable laser source to create a new class of optical instrumentation.

Accelerating bandwidth requirements are creating increased demand for higher bit rates and more channels. The filter's wavelength position, width, and shape are all becoming critical. As filter

widths move from 200 GHz to 25 GHz and lower, testing becomes more difficult.

## Wavelength Domain Component Analyzer

The Agilent 86082A wavelength domain component analyzer (WDCA) designed for the manufacture of narrow-wavelength filters, offers both high precision and fast measurement speeds in an easy-to-use instrument. An integrated system, the 86082A brings together the strengths of an optical spectrum analyzer (OSA) and a tunable laser source (TLS) to create a new class of optical instrumentation.

## Integrated instrument

The receiver in the 86082A has the large display, graphical user interface, and rich feature set of Agilent's OSA. Agilent's TLS provides the instrument's speed, wavelength range, resolution, and dynamic range. The 86082A includes a built-in calibration reference which provides the instrument with better than 5 pm absolute



wavelength accuracy. With its dual input channels, you can test two devices at the same time or, make reflection and insertion loss measurements.

## Optimize performance and measurement speed

Optimize the performance of the 86082A by selecting from three performance modes. *Normal* mode provides excellent accuracy and two sweeps per second over 2 nm. Select *precision* mode for increased accuracy. *Fast* mode allows wider spans and faster sweeps. *Fast* has very good specifications, while *normal* and *precision* offer even better performance.

## Ease of use

Forget linking and synchronization of an OSA and TLS. The 86082A has built-in stimulus response measurement functions. Extensive marker features and built-in measurement aids allow you to analyze and focus on the device under test.

You can also forget about accuracy changes with temperature. To maintain specified performance, the analyzer monitors the rate of temperature change and will display the projected time before the next user calibration will be required.

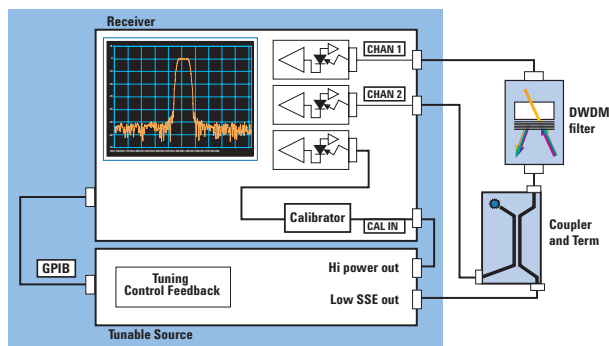

Block diagram of the 86082 showing a reflection and transmission measurement configuration



**Agilent Technologies**

For remote programming and automatic testing, the 86082A builds on the rich programming command set of Agilent's OSA family. As an integrated system, your programming efforts are focused on measurement results, rather than multiple instrument control.

Included with your analyzer is a CD-ROM with many routines and remote measurement examples ready to import into your remote controller.

### Wavelength Specifications<sup>1</sup>

	Precision mode	Normal mode	Fast mode
Range	1515 to 1575; 1480 to 1575 typical		
C-Band <sup>2</sup>	1515 to 1575; 1480 to 1575 typical		
L-Band <sup>3</sup>	1520 to 1620		
Accuracy			
C-Band <sup>2</sup>	±7 pm; ±5 pm typical	±7 pm; ±5.5 pm typical	±9 pm; ±7 pm typical
L-Band <sup>3</sup>	±9 pm; ±7 pm typical	±9 pm; ±7 pm typical	±11 pm; ±9 pm typical
Relative Accuracy			
≤ 1 nm delta	± 2 pm	± 2 pm	± 3 pm
≤ 20 nm delta	± 4 pm	± 4 pm	± 5 pm
Wavelength Resolution	± 10 MHz		
Wavelength Reproducibility	± 1.0 pm		

### Amplitude Specifications<sup>4</sup>

	Precision mode	Normal mode	Fast mode
Total Accuracy <sup>5</sup>			
Top 10 dB	± 0.05 dB	± 0.07 dB	± 0.9 dB
Full range	± 0.09 dB	± 0.1 dB	± 0.14 dB
Amplitude Stability			
Sweep to sweep	± 0.015 dB	± 0.02 dB	± 0.04 dB
Continuous over 4° C	± 0.04 dB	± 0.06 dB	± 0.8 dB
Polarization Dependent Loss (PDL)	± 0.025 dB		
Scale Fidelity			
< 10 dB insertion loss <sup>6</sup>		± 0.02 dB	
with Auto-Sensitivity		± 0.05 dB	
Full range		± 0.07 dB	
Dynamic Range at 7 pm offset			
Manual sensitivity		65 dB	
Auto-sensitivity		30 dB	
Receiver Noise Level	-85 dBm		

### General Specifications

	5 nm/Sec	10 nm/Sec	40 nm/Sec
Sweep Rate <sup>7</sup>	5 nm/Sec	10 nm/Sec	40 nm/Sec
Trace Update Rate	1 trace/sec over 2 nm	2 traces/sec over 2 nm	2 traces/sec over 8 nm
Auto-sensitivity on			

<sup>1</sup> Specifications describe the instrument's warranted performance. Typical and characteristics provide information about non-warranted performance.

<sup>2</sup> Option 86082A-111

<sup>3</sup> Option 86082A-112

<sup>4</sup> Not including connector repeatability.

<sup>5</sup> RSS of PDL, stability, and scale fidelity.

<sup>6</sup> Insertion loss is of the DUT, connectors, cabling, so on.

<sup>7</sup> 1000 data points (standard trace).

**For more assistance with your test & measurement needs  
or to find your local Agilent office go to**

[www.agilent.com/comms/lightwave](http://www.agilent.com/comms/lightwave)

Product specifications and descriptions in this document subject to change without notice.

© 2001, 2002 Agilent Technologies

Printed in USA April 22, 2002

5988-2150EN



**Agilent Email Updates**

[www.agilent.com/find/emailupdates](http://www.agilent.com/find/emailupdates)

Get the latest information on the products and applications you select.



**Agilent Technologies**