

VAR 3005A-S16

VOLTAGE SOURCE FOR DIPS, INTERRUPTS AND VARIATIONS TESTING



Teseq's VAR 3005A-S16 is a single phase motor variac that allows to steplessly adjust the EUT supply voltage from 0V to 260 V when supplied by a 230 V mains supply voltage. By means of the VAR 3005A-S16 tests as required in the standard IEC / EN 61000-4-11 (voltage dips and short interruptions as well as the optional voltage variation) can be performed adjusting the voltage to any voltage level. Apart from this the motor variac is used for power-frequency magnetic field tests as per IEC / EN 61000-4-8.

The motorized variac is designed primarily for use in combination with a generator from NSG 30x0A-series:

- Voltage range: 0 up to 260 V
- Max. current: 16 A cont., 40 A during > 3 s
- Frequency: 50 Hz/60 Hz
- Output voltage control: 0 - 10 VDC
- Fast slew rate, < 2 seconds (full range)
- High inrush current capability
- Steplessly adjustable output voltage
- Able to compensate mains supply variation

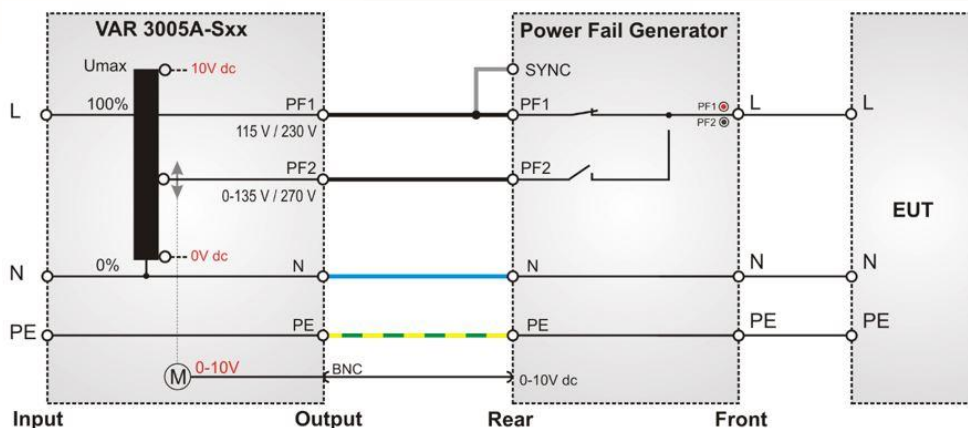

Voltage interruptions (DIPS) will cause a reduction of the power supply voltage for a certain period of time, three different test levels are required in IEC/EN 61000-4-11:

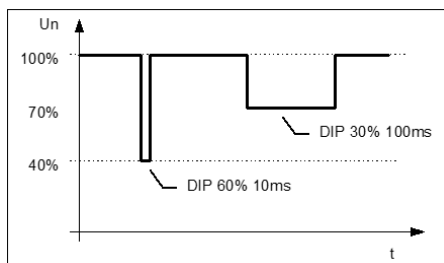

- Reduction by:
- 100% = reduction to 0% of the nominal voltage
 - 60% = reduction to 40% of the nominal voltage
 - 30% = reduction to 70% of the nominal voltage
 - 20% = reduction to 80% of the nominal voltage

Additionally it is possible to drive certain functions of **voltage variations**, which also are required in older versions of the standard IEC 61000-4-11. These functions can easily be programmed within the simulators itself or within the related windows software.

VAR 3005A-S16

VOLTAGE SOURCE FOR DIPS, INTERRUPTS AND VARIATIONS TESTING

Model	Output voltage
VAR 3005A-S16	0 – 260 V, 16 A @230 V supply voltage 0 – 130 V, 16 A @115 V supply voltage

Parameter	Value
Max input voltage:	max. 250 VAC
Frequency:	50 Hz / 60 Hz
Output voltage:	0 – 130 V @115 V supply voltage 0 – 260 V @230 V supply voltage 0 – 275 V @250 V supply voltage
Output current:	max. 16 A
Output power:	0 – 4.160 VA

Outputs	
Output PF 1	Nominal mains supply
Output PF 2	0 V – maximum output voltage (depending on supplied mains supply voltage)
Output connectors	4 mm safety lab connectors; PF1, PF2, Neutral and PE

Controls	
Mains switch	On / Off for the output voltage
Control voltage	Analog 0 – 10 V DC (0 V to max. output voltage)
Slew rate	< 2 seconds, full range

General data	VAR 3005A-S16
Dimensions:	19" / 6 HU, 266 mm x 485 mm x 400 mm (HxLxW)
Weight	app. 27 kg
Supply voltage:	115 / 230 V
Fuses:	20 A (PF1), 16 A (PF2)

Environment	
Temperature	10 °C to 35 °C
Humidity	30 % to 75 %, non-condensing
Atmospheric pressure	86 kPa (860 mbar) to 106 kPa (1.060 mbar)

AMETEK CTS GmbH
Sternenhofstr. 15 4153 Reinach Switzerland

© November 2019 AMETEK CTS
Specifications subject to change without notice.
This product is designed and manufactured under
the strict quality and environmental requirements
of the ISO 9001. This document has been carefully
checked. However, AMETEK CTS does not assume
any liability for errors or inaccuracies

November 2019