



Making a S11 and S21 Measurement Using the Agilent N9340A

Application Note



Introduction

Spectrum characteristics are important in wireless communication system maintenance. Network and spectrum analyzers are sometimes needed to measure the transmission and reflection characteristics of RF/Microwave devices such as amplifiers, filters, and antennas. But for when phase information from the DUT is unimportant, the Agilent N9340A handheld spectrum analyzer with tracking generator is an excellent choice. It provides spectrum analysis, transmission/reflection measurement, and, with the TG3 option, it scalar network analysis.

Transmission Measurement

Scalar transmission measurement is used to test the insertion gain and loss. Consider the following parameters in this process before testing.

Figure 1 Signal transmission and reflection

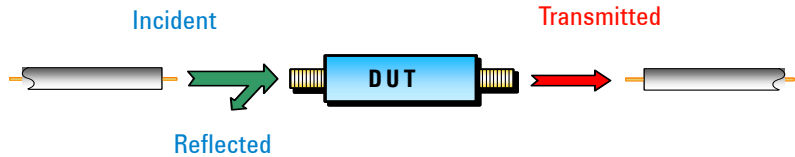

Transmission coefficient equals incident voltage divided by the transmitted voltage.

$$\tau = \frac{V_{Transmitted}}{V_{Incident}}$$

In 2-port network, S_{21} is described in dB as follows:

$$S_{21} = 20 \log(\tau)$$

The insertion loss value will be negative when S_{21} has a loss, and positive when the S_{21} has a gain.

Refer to [Figure 2](#) to setup the tracking system of the N9340A before measuring S_{21} . Connect the input of the DUT to the RF INPUT, and the output of the DUT to RF OUT. Then press the [MODE] hardkey and select **Tracking Generator** from the displayed menu, Tracking mode will be enabled after {Amplitude} is on.

Figure 2 Transmission coefficient measurement setup

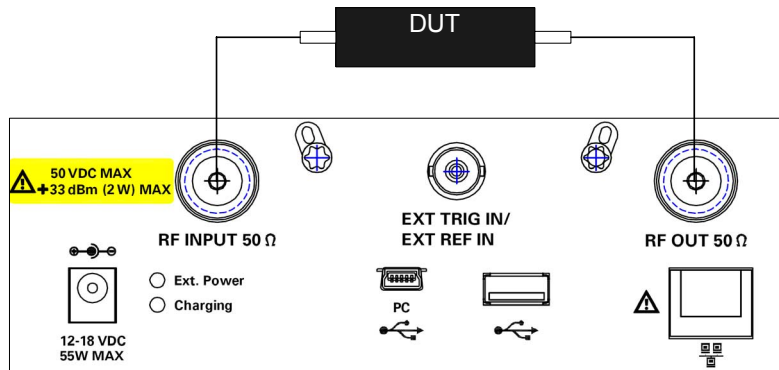

Follow the procedures below to measure the transmission coefficient: Set the frequency, resolution bandwidth, sweep time, input attenuation and tracking output amplitude for the DUT.

- 1 Replace the DUT with standard connector which directly links the RF OUT and the RF INPUT. Then turn on the **Normalize** function and set a reference point for 0 dB.
- 2 Replace the standard connector with the DUT. The readout is the transmission coefficient of DUT.

Follow the following procedure below to measure $|S_{21}|$ of a bandpass filter:

- 1 Turn on the {**Amplitude On Off**} and set the related parameters according to the specification of the filter (DUT). The filter pass-band ripple need to be measured, set the span so that it will not exceed the passband of the filter. Set the vertical grid to 1 dB/grid to obtain a better display resolution.

To measure the passband insertion loss and the stopband attenuation of filter, set the span larger than passband width and decrease the RBW appropriately to eliminate any DANL effect.

Note that the setup should not be changed during the next step. If it is, a normalize error will occur, resulting in an incorrect measurement.

- 2 Directly connect the RF OUT to the RF IN before making a measurement so that the incident signal from RF OUT will be normalized as the reference signal. Failure to following this step will result in a uneven spectrum.

Connect the RF OUT to the RF INPUT without the filter. Following the procedure below to normalize the signal after completing a single sweep:

[MEAS] > {**Normalize (Off)**} > {**Store Ref 1 → 4**} > {**Normalize On**}

It will yield a flat normalized spectrum. Press {**Norm Ref Lvl**} to adjust the spectrum position on the display.

- 3 Connect the filter with RF OUT and RF IN to measure the transmission coefficient. Turning on the average function will flatten the spectrum and decrease the random errors.

Reflection Measurement

The scalar reflection measurement describes how much energy is absorbed in the incident wave and reveals the mismatch between DUT and the transmission line of characteristic impedance Z_0 (typical 50Ω). Usually the output energy is partially absorbed by the receiver, while the rest is reflected back to the source. To determine the transmission efficiency, measure the incident and reflected signal. Define reflectance γ as [Figure 1](#):

$$\gamma = \frac{V_{Reflected}}{V_{Incident}}$$

Then use S_{11} instead of reflectance γ in network theory as follow in dB:

$$S_{11} = 20 \log (\gamma)$$

Reflectance equals incident voltage divided by reflected voltage. A terminal which is absolutely matched with the characteristic impedance transmission line, absorbs all the output energy: reflectance $\gamma=0$. If an open or short circuit is connected with the characteristic impedance transmission line, the reflectance is $|\gamma|=1$ meaning all the energy is reflected back to the source. Consequently S_{11} is generally between 0 and $-\infty$ dB, except some active circuits such as oscillator with a S_{11} larger than 0 dB.

As with transmission measurement, we must setup the N9340A's parameter controls must be set up and open the tracking mode before making a reflection measurement. In particular, a signal separating device like an electronic bridge or directional coupler should be placed between the input and reflected signal.

Figure 3 Reflection coefficient measurement setup

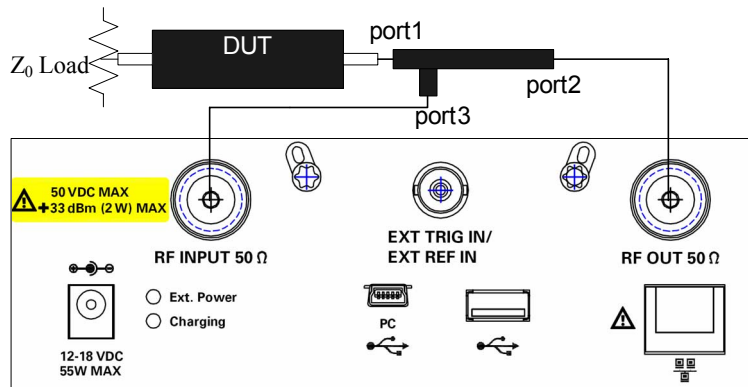

Connect the RF OUT to Port 2 of the directional coupler. Connect the DUT to Port 1. Connect the isolation arm to RF IN. In [Figure 3](#), Port2 and 3 are the isolation ports; port1 and port3 are coupled ports, and while Port1 and 2 are through ports pair.

Follow the steps below to measure the reflectance:

- 1 Set frequency, resolution bandwidth, sweep time, input attenuation, and output signal amplitude properly.
- 2 Replace the DUT with an open or short, turn on the normalize function and set the reference point to 0 dB.
- 3 Replace the open or short with the DUT. The readout of measurement is the reflectance of the DUT.

The procedure for measuring $|S_{11}|$ is similar to the transmission coefficient measurement.

- 1 Turn on tracking output, and set the corresponding parameters including frequency range, resolution width, input attenuation and tracking power according to the filter's specification. Note that a confirmed setup should not be changed during the next step or a normalize error will occur and the resulting measurement will be incorrect.
- 2 Determine a reference voltage before making the reflection measurement. Use reflected power from an open as reference voltage. Replace the DUT in [Figure 3](#) with an open. After total reflection the reflected wave enters the analyzer's RF INPUT through the directional coupler. Set reference power to 0 dB (Total reflection $|r|=1$, $20 \lg 1 = 0$ dB). After connecting an open correctly and completing a sweep, normalize the analyzer as follow: **[MEAS] > {Amplitude On} > {Normalize OFF} > {Store Ref 1->4} > {Normalize On}**.
- 3 Replace the open with the DUT, a bandpass filter. Connect the other port of the filter to a 50Ω matched load for a $|s_{11}|$ measurement. Now the spectrum equals the reflectance $|s_{11}|$.

Measurement Result

The measurement results of $|S_{11}|$ and $|S_{21}|$ in the examples above are the curves in Figure 4.

Common measurement errors can be avoided by following these recommendations:

Errors due to tracking frequency response can be eliminated by normalization.

Scale fidelity errors can be avoided by increasing the N9340A tracking output power to the maximum level tolerated by the DUT.

Errors due to mismatch can be avoided by decreasing the source and load matching. For example, connect a 10 dB attenuator in series between the RF OUT and the RF INPUT of the N9340A.

Figure 4 Screenshot of filter $|S_{21}|$ and $|S_{11}|$ measurement

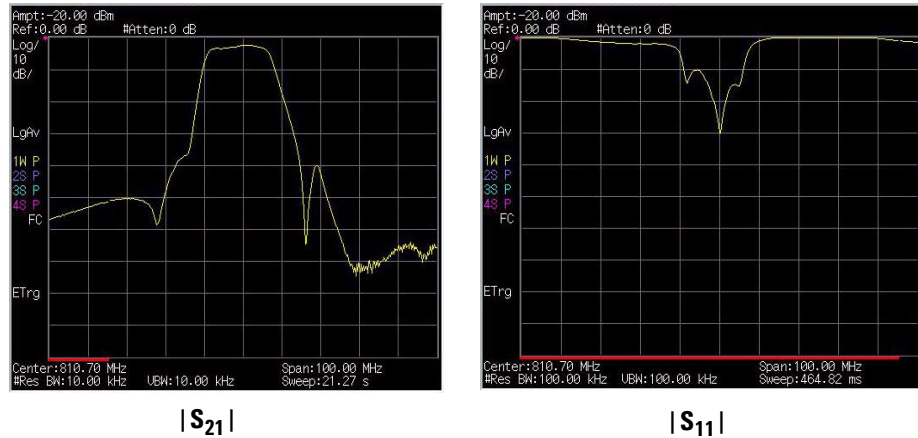

Reflectance measurements often produce errors because of the directivity of directional coupler, a mismatch between source and load impedance, scale fidelity, or normalization of a short or open. A directional coupler with good direction, such as Agilent 86205A with 40 dB high directivity will decrease these errors. Connecting a 10 dB attenuator in series between the DUT and coupler will improve matching.

Please refer to Agilent Application Note 5966-1650E for more information about avoiding measurement errors.



Agilent Email Updates

www.agilent.com/find/emailupdates
Get the latest information on the products and applications you select.



Agilent Direct

www.agilent.com/find/agilentdirect
Quickly choose and use your test equipment solutions with confidence.

www.agilent.com

For more information on Agilent Technologies' products, applications or services, please contact your local Agilent office. The complete list is available at:

www.agilent.com/find/contactus

Americas

Canada	(877) 894-4414
Latin America	305 269 7500
United States	(800) 829-4444

Asia Pacific

Australia	1 800 629 485
China	800 810 0189
Hong Kong	800 938 693
India	1 800 112 929
Japan	81 426 56 7832
Korea	080 769 0800
Malaysia	1 800 888 848
Singapore	1 800 375 8100
Taiwan	0800 047 866
Thailand	1 800 226 008

Europe

Austria	0820 87 44 11
Belgium	32 (0) 2 404 93 40
Denmark	45 70 13 15 15
Finland	358 (0) 10 855 2100
France	0825 010 700
Germany	01805 24 6333*
	*0.14€/minute
Ireland	1890 924 204
Italy	39 02 92 60 8484
Netherlands	31 (0) 20 547 2111
Spain	34 (91) 631 3300
Sweden	0200-88 22 55
Switzerland (French)	41 (21) 8113811(Opt 2)
Switzerland (German)	0800 80 53 53 (Opt 1)
United Kingdom	44 (0) 118 9276201

Other European Countries:

www.agilent.com/find/contactus

Revised: May 7, 2007

Product specifications and descriptions in this document subject to change without notice.

© Agilent Technologies, Inc. 2007
Printed in USA, November 16, 2007
5989-7661EN



Agilent Technologies