

NOTES:
 1. SEE SHEETS 2 - 9 FOR UNSPECIFIED NOTES, DIMENSIONS & PART NUMBERS

THIS DRAWING CONTAINS INFORMATION THAT IS PROPRIETARY TO MOLEX ELECTRONIC TECHNOLOGIES, LLC AND SHOULD NOT BE USED WITHOUT WRITTEN PERMISSION													
QUALITY SYMBOLS ▽A = 0 ▽E = 0 ▽F = 0 ▽ = 0 ▽C = 0 ⊠ = 0 ■ = 0 ▽ = 0	SEE LONG TEXT EC NO: 111526 DRWN: JFLETCHER CHK'D: FDUGGAN APPR: JDWALLACE	GENERAL TOLERANCES (UNLESS SPECIFIED)		DIMENSION UNITS	SCALE								
		ANGULAR TOL ± 2.0 °		MM	1.5:1								
		4 PLACES ±	DRWN BY		DATE		8CCT ML-Xt CV CONNECTOR SYSTEM						
		3 PLACES ±	JFLETCHER		2016/01/05								
		2 PLACES ± 0.1	CHK'D BY		DATE		PRODUCT CUSTOMER DRAWING						
		1 PLACE ± 0.2	FDUGGAN		2016/01/12								
		0 PLACES ±	APPR BY		DATE		SERIES		MATERIAL NUMBER		CUSTOMER		
		DRAFT WHERE APPLICABLE MUST REMAIN WITHIN DIMENSIONS	JDWALLACE		2016/01/14		93443		SEE NOTES		GENERAL MARKET		
			DRAWING SIZE		THIRD ANGLE PROJECTION		DOCUMENT NUMBER		DOC TYPE		DOC PART	SHEET NUMBER	
			A3				934430050		PSD		000	1 OF 9	

8CCT RECEPTACLE CONNECTOR

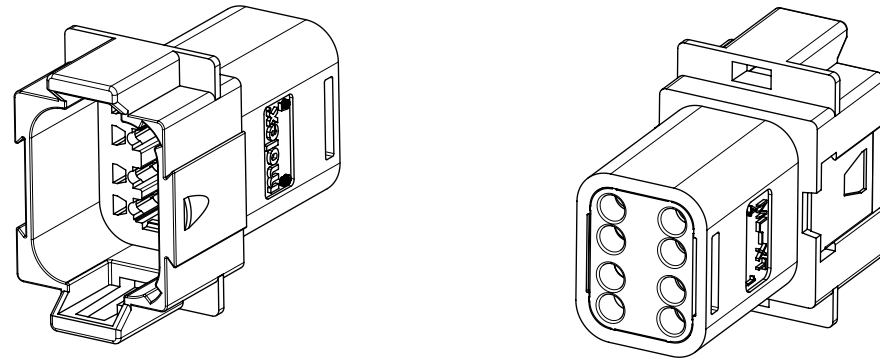

8CCT RECEPTACLE CONNECTOR WITH HEATSHRINK HOUSING ULTRASONICALLY WELDED IN PLACE

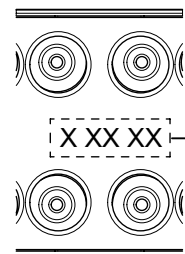
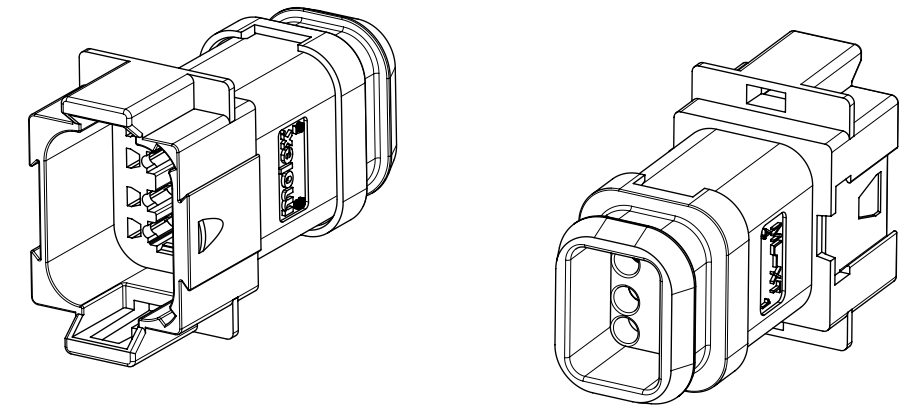

DETAIL A
SCALE 2:1

DATE CODE: X XX XX
X — DAY: 1-7

X — WEEK: 01 - 52

X — YEAR: 00 - 99

— MACHINE NO. 1

EXAMPLE: 11315 = DAY 1, WEEK 13, YEAR 15
i.e. 23rd OF MARCH 2015

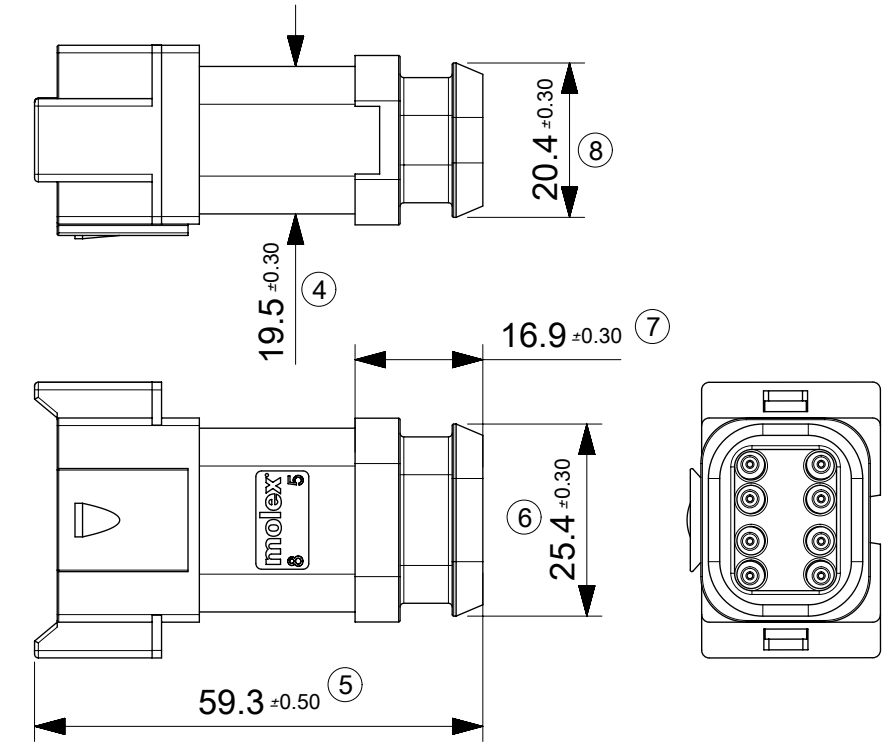
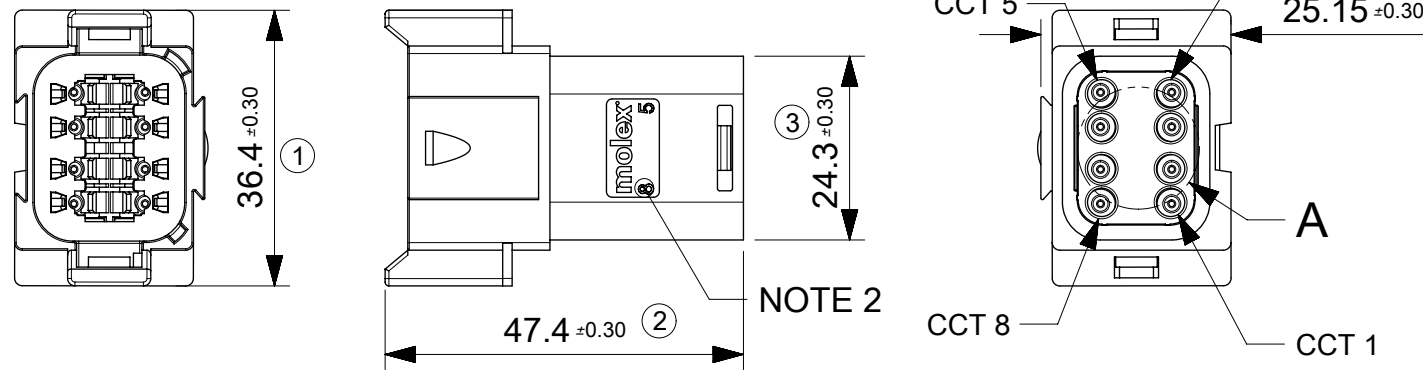

NOTES

- MATERIAL
HOUSING: NYLON 30% GF
BACK SEAL: HIGH CONSISTENCY RUBBER
 - CIRCUIT IDENTIFICATION
 - JACKET RANGE LARGE = Ø2.7MM TO 3.6MM (SEAL COLOUR: LIGHT BLUE)
JACKET RANGE SMALL = Ø1.4MM TO 2.7MM (SEAL COLOUR: BURNT ORANGE)
 - SEE SHEET 3 FOR FINAL PART NUMBER DESIGNATION
 - SEE 934430010 PS P FOR PRODUCT SPECIFICATION
 - SEE 934430002 PS K OR 934430010 PS K FOR PACKAGING SPECIFICATION
- INSPECTION NUMBERS 1-50 RESERVED FOR SHEET 2
LAST INSPECTION NUMBER: 9

QUALITY SYMBOLS		THIS DRAWING CONTAINS INFORMATION THAT IS PROPRIETARY TO MOLEX ELECTRONIC TECHNOLOGIES, LLC AND SHOULD NOT BE USED WITHOUT WRITTEN PERMISSION			
▽A = 0	2016/11/16	GENERAL TOLERANCES (UNLESS SPECIFIED)		DIMENSION UNITS	SCALE
▽E = 0	2016/11/18	ANGULAR TOL ± 2.0 °		MM	1:1
▽F = 0	2017/06/06	4 PLACES ±		DRWN BY	DATE
▽ = 0		3 PLACES ±		JFLETCHER	2016/01/05
▽C = 0		2 PLACES ± 0.1		CHK'D BY	DATE
▽ = 0		1 PLACE ± 0.2		FDUGGAN	2016/01/12
▽ = 0		0 PLACES ±		APPR BY	DATE
▽ = 0				JDWALLACE	2016/01/14
▽ = 0				DRAWING SIZE	THIRD ANGLE PROJECTION
				A3	
		DRAFT WHERE APPLICABLE MUST REMAIN WITHIN DIMENSIONS			
EC NO: 111526 DRWN: JFLETCHER CHK'D: FDUGGAN APPR: JDWALLACE		8CCT ML-XT CV CONNECTOR SYSTEM PRODUCT CUSTOMER DRAWING			
SEE LONG TEXT A1		SERIES	MATERIAL NUMBER	CUSTOMER	
		93443	SEE NOTES	GENERAL MARKET	
		DOCUMENT NUMBER		DOC TYPE	DOC PART
		934430050		PSD	000
				SHEET NUMBER	
				2 OF 9	

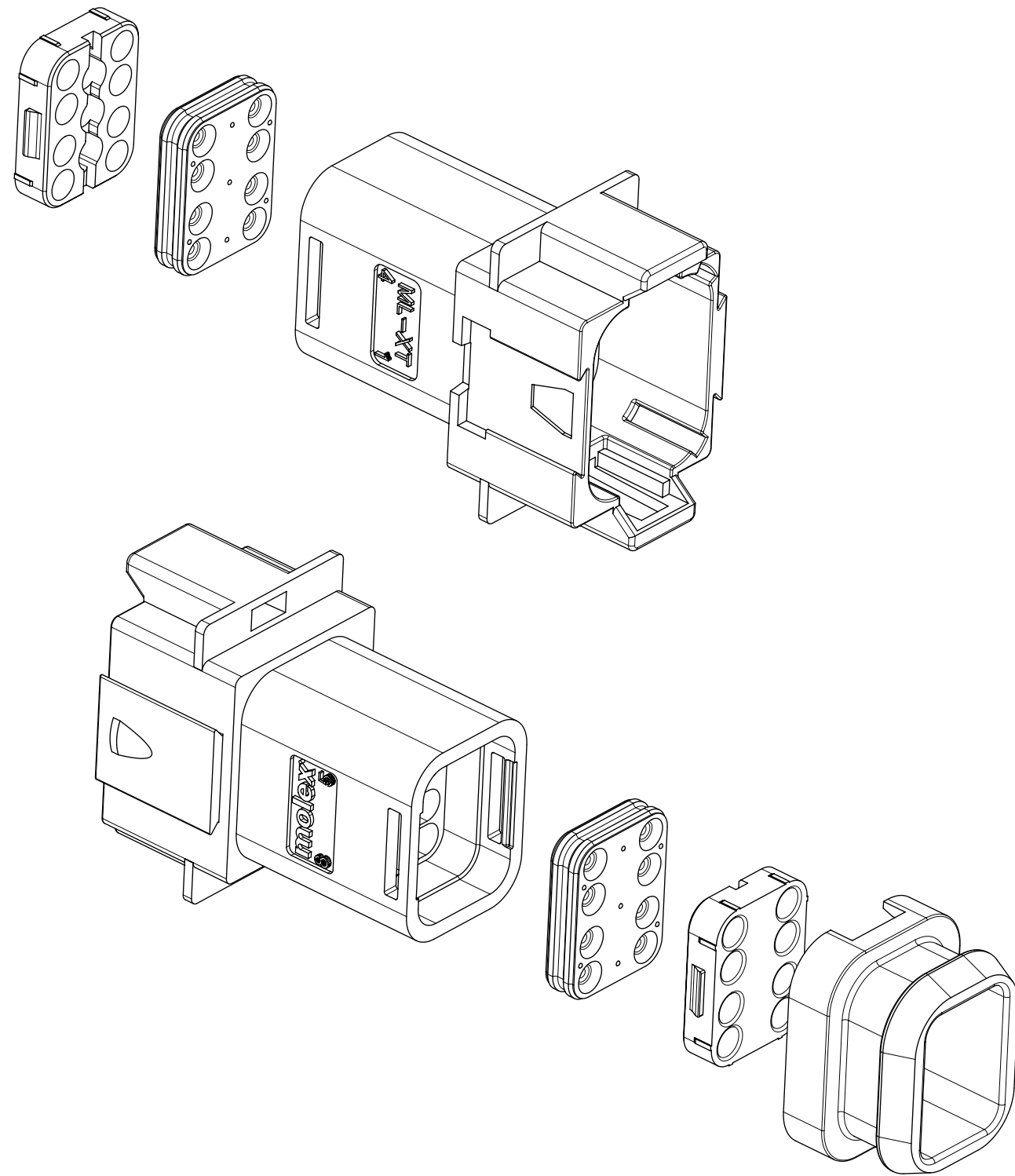

8CCT RECEPTACLE CONNECTOR

SERIES NO.

93444

CIRCUIT SIZE
5 = 8CCT

5

-

-

ASSEMBLY OPTIONS

- 1 = RECEPTACLE ASSEMBLY FOR WIRE JACKET RANGE \varnothing 1.4mm - 2.7mm
- 2 = RECEPTACLE ASSEMBLY FOR WIRE JACKET RANGE \varnothing 2.7mm - 3.6mm
- 5 = RECEPTACLE ASSEMBLY & HEATSHRINK FOR WIRE JACKET RANGE \varnothing 1.4mm - 2.7mm
- 6 = RECEPTACLE ASSEMBLY & HEATSHRINK FOR WIRE JACKET RANGE \varnothing 2.7mm - 3.6mm

KEYING / COLOUR OPTION

- 12 = KEYING OPTION A (GREY)
- 21 = KEYING OPTION B (BLACK)
- 33 = KEYING OPTION C (GREEN)
- 47 = KEYING OPTION D (BROWN)

EXAMPLE:

8CCT RECEP & HEATSHRINK FOR WIRE JACKET RANGE \varnothing 1.4mm-2.7mm, KEYING OPTION A (GREY): 93444-5512

NOTES

1. SEE SHEET 2 FOR UNSPECIFIED NOTES AND DIMENSIONS
2. BACK COVER COLOUR: BLACK
3. HEATSHRINK HOUSING COLOUR: BLACK

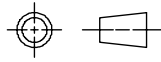
THIS DRAWING CONTAINS INFORMATION THAT IS PROPRIETARY TO MOLEX ELECTRONIC TECHNOLOGIES, LLC AND SHOULD NOT BE USED WITHOUT WRITTEN PERMISSION														
QUALITY SYMBOLS ▽A = 0 ▽E = 0 ▽F = 0 ▼ = 0 ▽C = 0 ⊗ = 0 ■ = 0 ▽ = 0	SEE LONG TEXT EC NO: 111526 DRWN: JFLETCHER CHK'D: FDUGGAN APPR: JDWALLACE	GENERAL TOLERANCES (UNLESS SPECIFIED) ANGULAR TOL \pm 2.0 °		DIMENSION UNITS MM	SCALE 1.5:1	 8CCT ML-XT CV CONNECTOR SYSTEM								
		4 PLACES \pm	3 PLACES \pm	2 PLACES \pm 0.1	1 PLACE \pm 0.2							0 PLACES \pm	DRWN BY JFLETCHER	DATE 2016/01/05
		DRAFT WHERE APPLICABLE MUST REMAIN WITHIN DIMENSIONS		DRAWING SIZE A3	THIRD ANGLE PROJECTION 	PRODUCT CUSTOMER DRAWING			SERIES 93443	MATERIAL NUMBER SEE NOTES	CUSTOMER GENERAL MARKET			
		RELEASE STATUS P1				RELEASE DATE 06.06.2017 08:12:51				DOCUMENT NUMBER 934430050		DOC TYPE PSD	DOC PART 000	SHEET NUMBER 3 OF 9

9 8 7 6 5 4 3 2 1

KEYING OPTION A

KEYING OPTION B

KEYING OPTION C

KEYING OPTION D

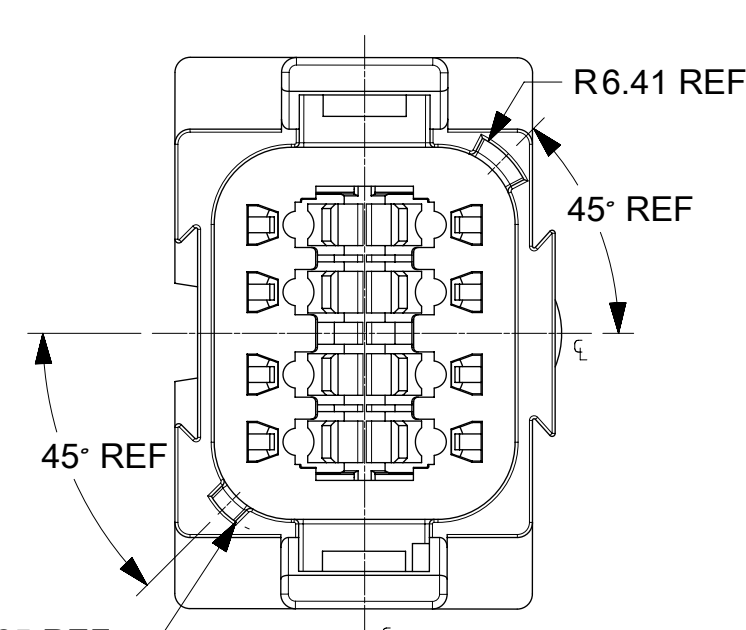
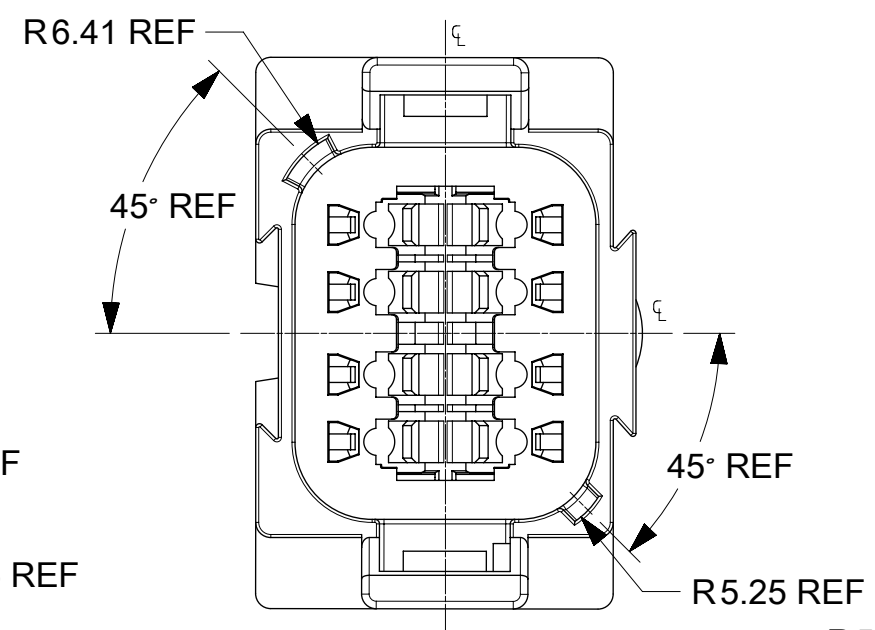
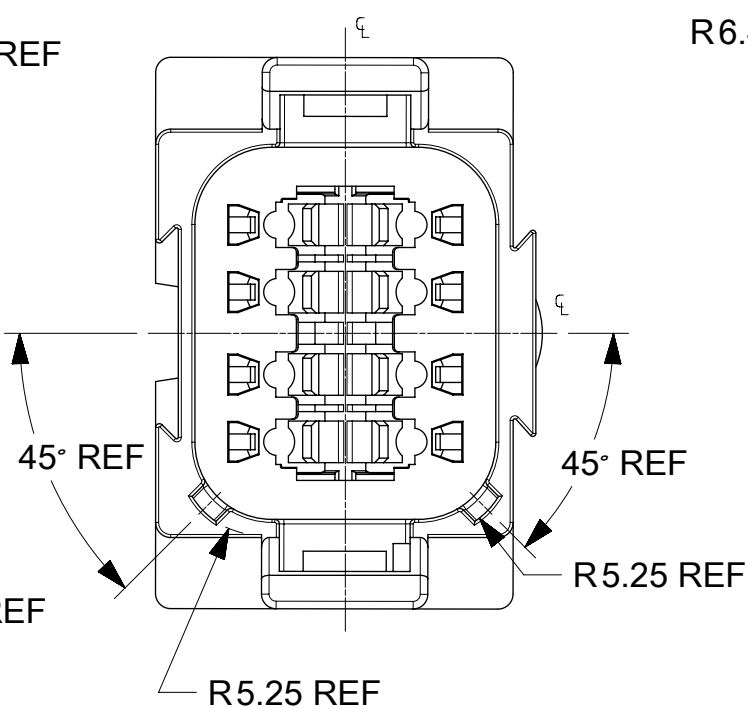
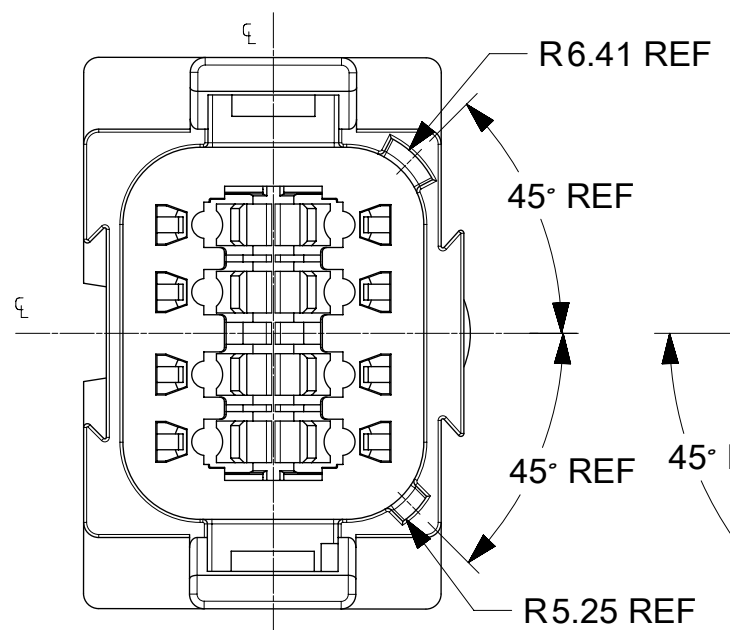
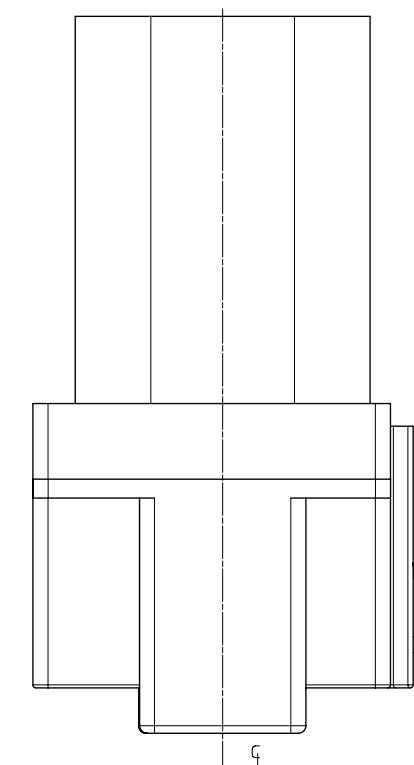
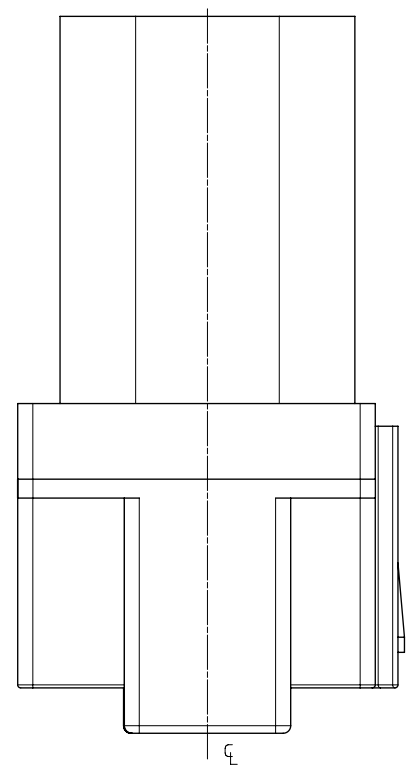
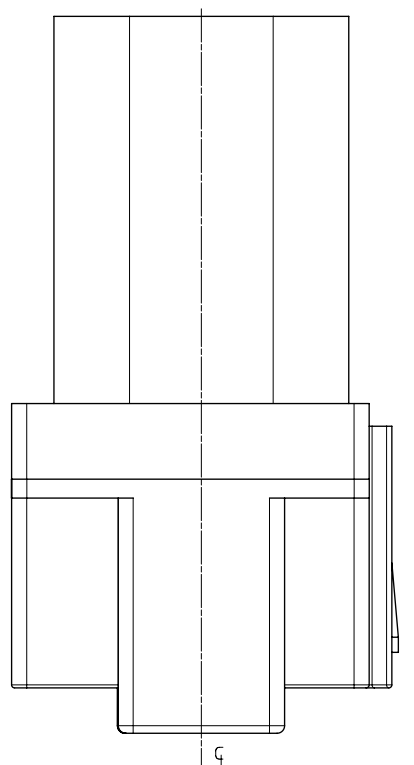
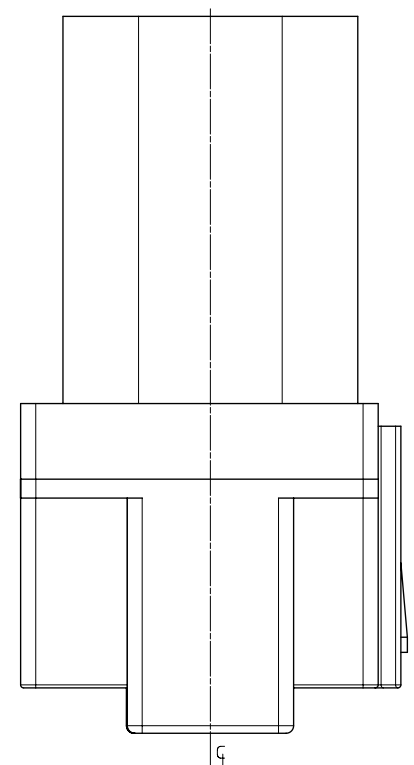

NOTES:
1. SEE SHEETS 2 & 3 FOR UNSPECIFIED NOTES & DIMENSIONS

QUALITY SYMBOLS ▽A = 0 ▽E = 0 ▽F = 0 ▼ = 0 ▽C = 0 ⊠ = 0 ■ = 0 ▽ = 0	THIS DRAWING CONTAINS INFORMATION THAT IS PROPRIETARY TO MOLEX ELECTRONIC TECHNOLOGIES, LLC AND SHOULD NOT BE USED WITHOUT WRITTEN PERMISSION											
	EC NO: 111526 DRWN: JFLETCHER CHK'D: FDUGGAN APPR: JDWALLACE	2016/11/16 2016/11/18 2017/06/06	GENERAL TOLERANCES (UNLESS SPECIFIED)		DIMENSION UNITS	SCALE						
			ANGULAR TOL ± 2.0 °		MM	2:1						
			4 PLACES ±	DRWN BY		DATE		8CCT ML-XT CV CONNECTOR SYSTEM				
			3 PLACES ±	JFLETCHER		2016/01/05						
			2 PLACES ± 0.1	CHK'D BY		DATE						
	1 PLACE ± 0.2	FDUGGAN		2016/01/12		PRODUCT CUSTOMER DRAWING						
	0 PLACES ±	APPR BY		DATE								
	DRAFT WHERE APPLICABLE MUST REMAIN WITHIN DIMENSIONS		JDWALLACE		2016/01/14		SERIES	MATERIAL NUMBER	CUSTOMER			
			A3		THIRD ANGLE PROJECTION		93443	SEE NOTES	GENERAL MARKET			
		A1		A3		DOCUMENT NUMBER		DOC TYPE	DOC PART	SHEET NUMBER		
						934430050		PSD	000	4 OF 9		

9 8 7 6 5 4 3 2 1

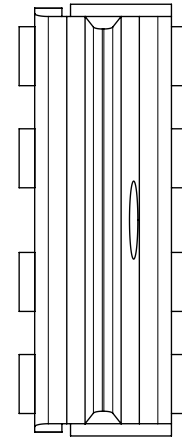
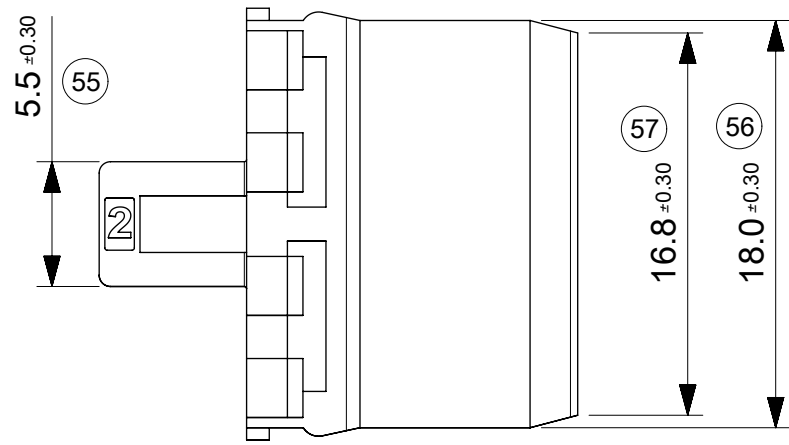
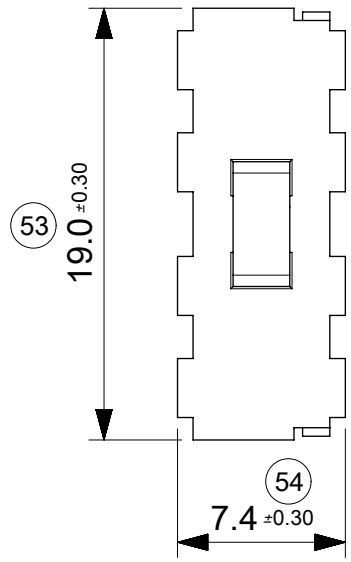
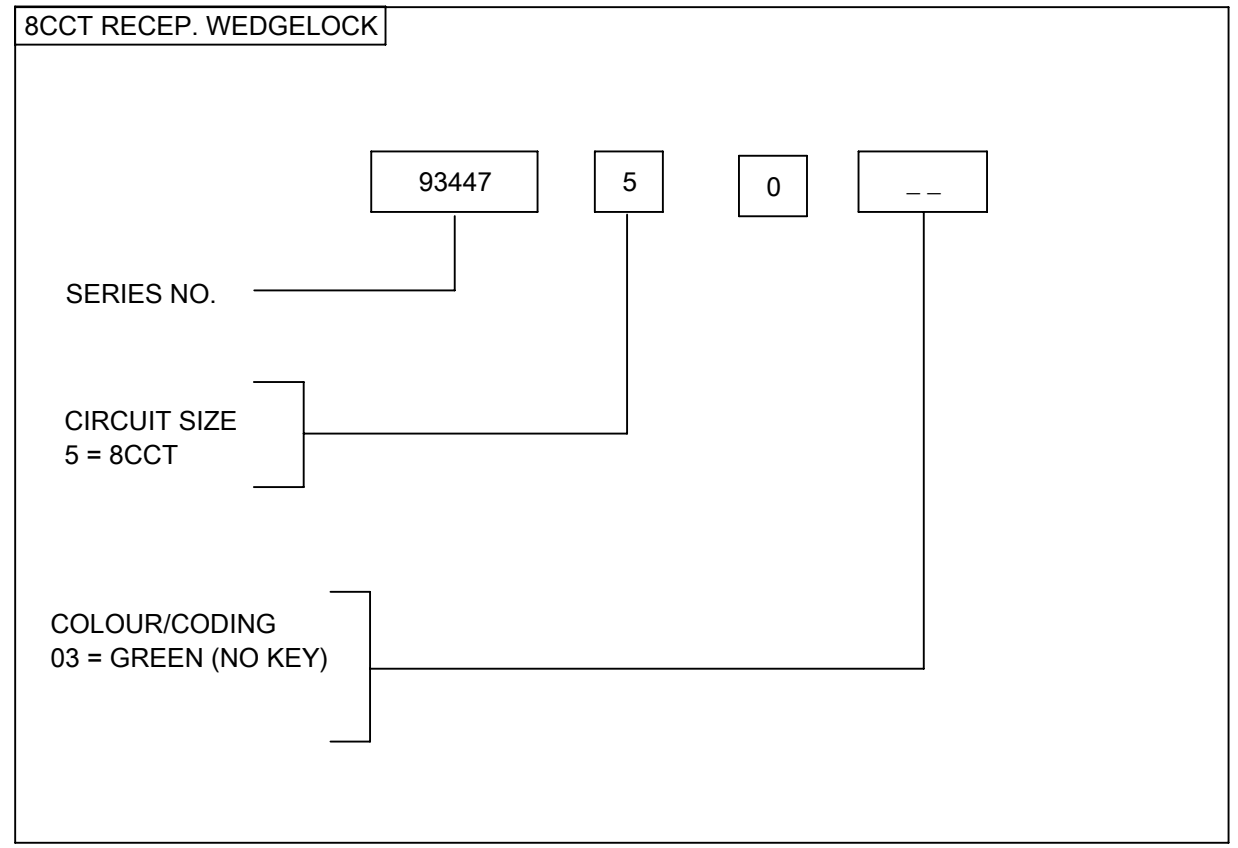
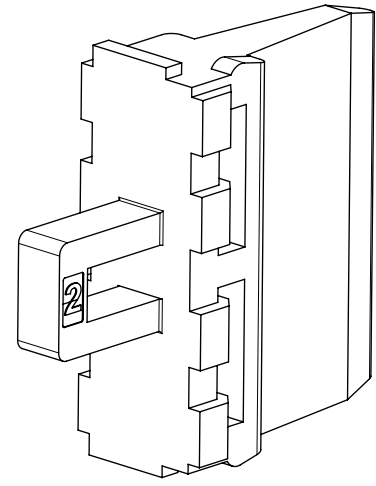
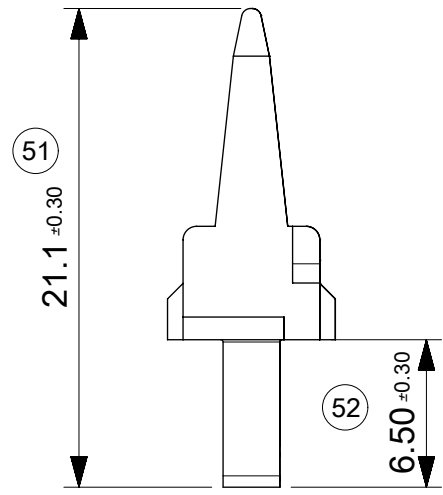

NOTES:
 1. MATERIAL: NYLON, 30% GLASS FILLED
 INSPECTION NUMBERS 51 - 100 USED FOR SHEET 5.
 LAST INSPECTION NUMBER 57

THIS DRAWING CONTAINS INFORMATION THAT IS PROPRIETARY TO MOLEX ELECTRONIC TECHNOLOGIES, LLC AND SHOULD NOT BE USED WITHOUT WRITTEN PERMISSION																	
QUALITY SYMBOLS		2016/11/16 2016/11/18 2017/06/06		GENERAL TOLERANCES (UNLESS SPECIFIED)		DIMENSION UNITS		SCALE									
▽A	= 0	SEE LONG TEXT	EC NO: 111526 DRWN: JFLETCHER CHK'D: FDUGGAN APPR: JDWALLACE	ANGULAR TOL ± 2.0 °		MM		3:1				8CCT ML-XT CV CONNECTOR SYSTEM					
▽E	= 0			4 PLACES	±	DRWN BY		DATE									
▽F	= 0			3 PLACES	±	JFLETCHER		2016/01/05									
▽	= 0			2 PLACES	± 0.1	CHK'D BY		DATE		PRODUCT CUSTOMER DRAWING							
▽C	= 0			1 PLACE	± 0.2	FDUGGAN		2016/01/12									
⊠	= 0			0 PLACES	±	APPR BY		DATE		SERIES		MATERIAL NUMBER		CUSTOMER			
■	= 0	DRAFT WHERE APPLICABLE MUST REMAIN WITHIN DIMENSIONS		JDWALLACE		2016/01/14		93443		SEE NOTES		GENERAL MARKET					
▽	= 0			DRAWING SIZE		THIRD ANGLE PROJECTION		A3		DOCUMENT NUMBER		DOC TYPE		DOC PART		SHEET NUMBER	
										934430050		PSD		000		5 OF 9	

8CCT PLUG CONNECTOR

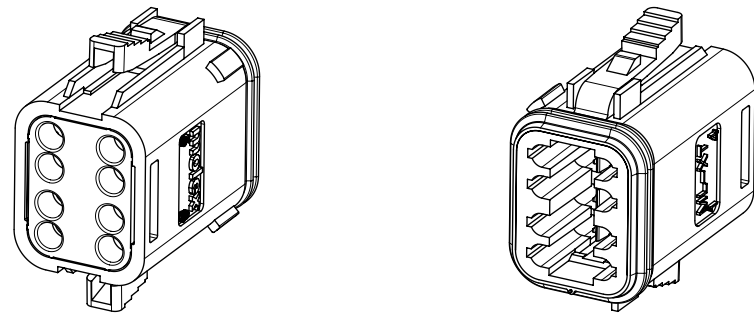

8CCT PLUG CONNECTOR WITH HEATSHRINK HOUSING ULTRASONICALLY WELDED IN PLACE



DATE CODE: X XX XX
 X — DAY: 1- 7
 X — WEEK: 01 - 52
 X — YEAR: 00 - 99
 # — MACHINE NO. 1
 EXAMPLE: 11315 = DAY 1, WEEK 13, YEAR 15
 i.e. 23rd OF MARCH 2015

DETAIL B
 SCALE 2:1

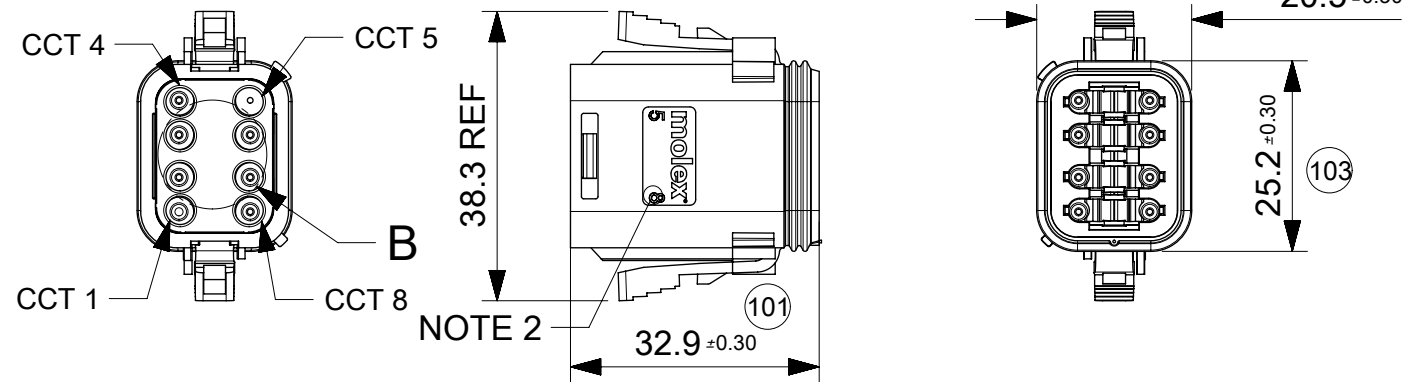

NOTES

- MATERIAL
 HOUSING: NYLON 30% GF
 PLUG SEAL: SILICONE
 BACK SEAL: HIGH CONSISTENCY RUBBER
 - CIRCUIT IDENTIFICATION
 - JACKET RANGE LARGE = \varnothing 2.7MM TO 3.6MM (SEAL COLOUR: LIGHT BLUE)
 JACKET RANGE SMALL = \varnothing 1.4MM TO 2.7MM (SEAL COLOUR: BURNT ORANGE)
 - SEE SHEET 3 FOR FINAL PART NUMBER DESIGNATION
 - SEE 934430010 PS P FOR PRODUCT SPECIFICATION
 - SEE 934430002 PS K OR 934430010 PS K FOR PACKAGING SPECIFICATION
- INSPECTION NUMBERS 101-150 RESERVED FOR SHEET 6
 LAST INSPECTION NUMBER: 106

THIS DRAWING CONTAINS INFORMATION THAT IS PROPRIETARY TO MOLEX ELECTRONIC TECHNOLOGIES, LLC AND SHOULD NOT BE USED WITHOUT WRITTEN PERMISSION													
QUALITY SYMBOLS ▽ = 0 ▽ = 0 ▽ = 0 ▼ = 0 ▽ = 0 ⊠ = 0 ■ = 0 ▽ = 0	SEE LONG TEXT EC NO: 111526 DRWN: JFLETCHER CHK'D: FDUGGAN APPR: JDWALLACE	GENERAL TOLERANCES (UNLESS SPECIFIED)		DIMENSION UNITS	SCALE								
		4 PLACES ±		MM	1:1								
		3 PLACES ±		DRWN BY JFLETCHER		DATE 2016/01/05		8CCT ML-XT CV CONNECTOR SYSTEM					
		2 PLACES ± 0.1		CHK'D BY FDUGGAN		DATE 2016/01/12							
		1 PLACE ± 0.2		APPR BY JDWALLACE		DATE 2016/01/14		PRODUCT CUSTOMER DRAWING					
		0 PLACES ±		DRAFT WHERE APPLICABLE MUST REMAIN WITHIN DIMENSIONS		DRAWING SIZE	THIRD ANGLE PROJECTION						
						A3		93443	SEE NOTES	GENERAL MARKET			
									DOCUMENT NUMBER	DOC TYPE	DOC PART	SHEET NUMBER	
									934430050	PSD	000	6 OF 9	

8CCT PLUG CONNECTOR

SERIES NO.

93445

CIRCUIT SIZE
5 = 8CCT

ASSEMBLY OPTIONS

- 1 = PLUG ASSEMBLY FOR WIRE JACKET RANGE \varnothing 1.4mm - 2.7mm
- 2 = PLUG ASSEMBLY FOR WIRE JACKET RANGE \varnothing 2.7mm - 3.6mm
- 5 = PLUG ASSEMBLY & HEATSHRINK FOR WIRE JACKET RANGE \varnothing 1.4mm - 2.7mm
- 6 = PLUG ASSEMBLY & HEATSHRINK FOR WIRE JACKET RANGE \varnothing 2.7mm - 3.6mm

KEYING / COLOUR OPTION

- 12 = KEYING OPTION A (GREY)
- 21 = KEYING OPTION B (BLACK)
- 33 = KEYING OPTION C (GREEN)
- 47 = KEYING OPTION D (BROWN)

EXAMPLE:

8CCT PLUG & HEATSHRINK FOR WIRE JACKET RANGE \varnothing 1.4mm-2.7mm, KEYING OPTION A (GREY): 93445-5512

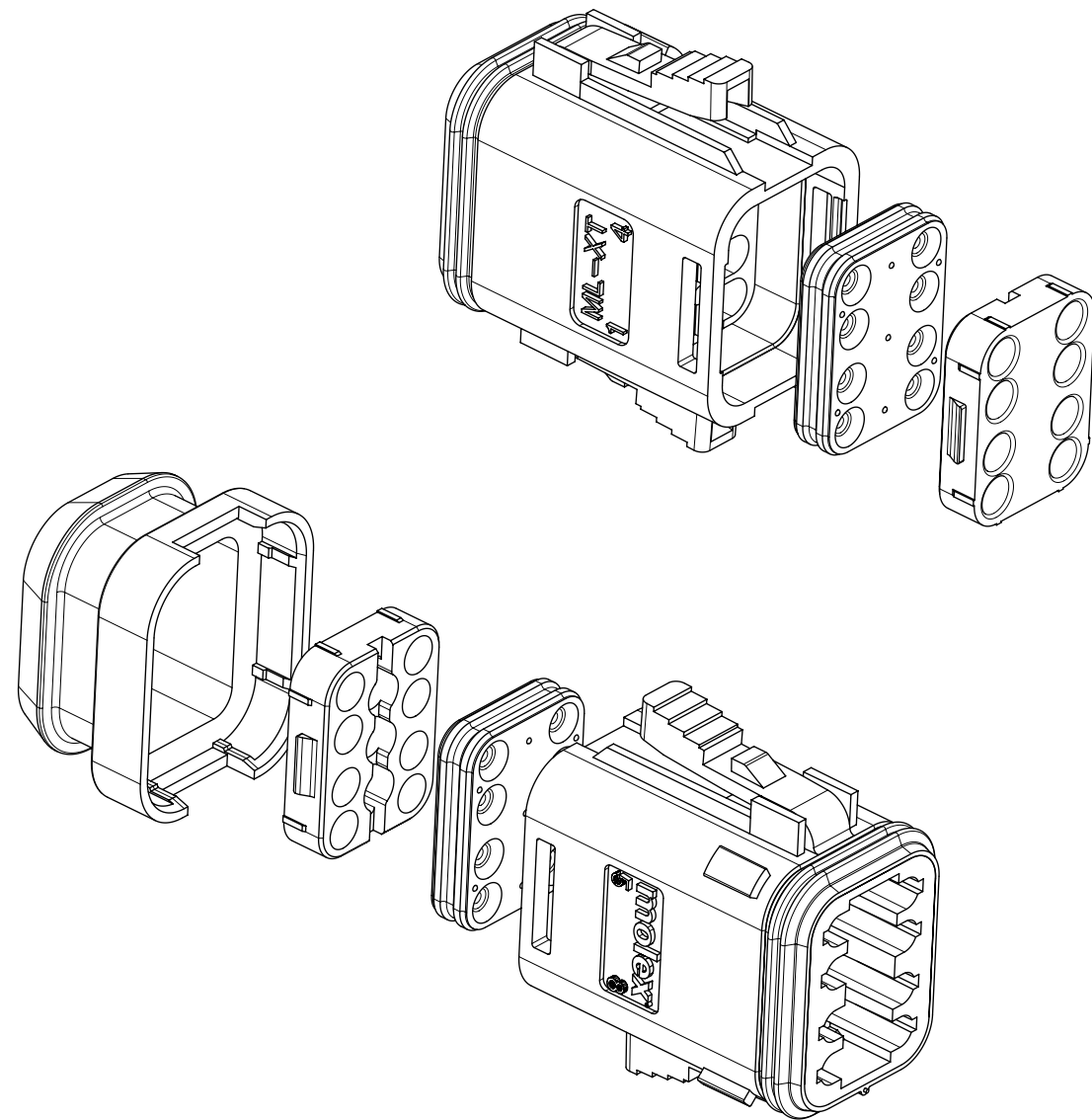

NOTES

1. SEE SHEET 6 FOR UNSPECIFIED NOTES AND DIMENSIONS
2. BACK COVER COLOUR: BLACK
3. HEATSHRINK HOUSING COLOUR: BLACK

THIS DRAWING CONTAINS INFORMATION THAT IS PROPRIETARY TO MOLEX ELECTRONIC TECHNOLOGIES, LLC AND SHOULD NOT BE USED WITHOUT WRITTEN PERMISSION													
QUALITY SYMBOLS ▽A = 0 ▽E = 0 ▽F = 0 ▽G = 0 ▽H = 0 ▽I = 0 ▽J = 0 ▽K = 0 ▽L = 0	SEE LONG TEXT EC NO: 111526 DRWN: JFLETCHER CHK'D: FDUGGAN APPR: JDWALLACE	GENERAL TOLERANCES (UNLESS SPECIFIED) ANGULAR TOL \pm 2.0 °		DIMENSION UNITS MM	SCALE 1.5:1	 8CCT ML-XT CV CONNECTOR SYSTEM							
		4 PLACES \pm	3 PLACES \pm	2 PLACES \pm 0.1	1 PLACE \pm 0.2							0 PLACES \pm	DRWN BY JFLETCHER
		DRAFT WHERE APPLICABLE MUST REMAIN WITHIN DIMENSIONS					CHK'D BY FDUGGAN	DATE 2016/01/12	PRODUCT CUSTOMER DRAWING SERIES: 93443 MATERIAL NUMBER: SEE NOTES CUSTOMER: GENERAL MARKET				
		DRAWING SIZE A3		THIRD ANGLE PROJECTION			APPR BY JDWALLACE						
						DOCUMENT NUMBER 934430050		DOC TYPE PSD	DOC PART 000	SHEET NUMBER 7 OF 9			

KEYING OPTION A

KEYING OPTION B

KEYING OPTION C

KEYING OPTION D

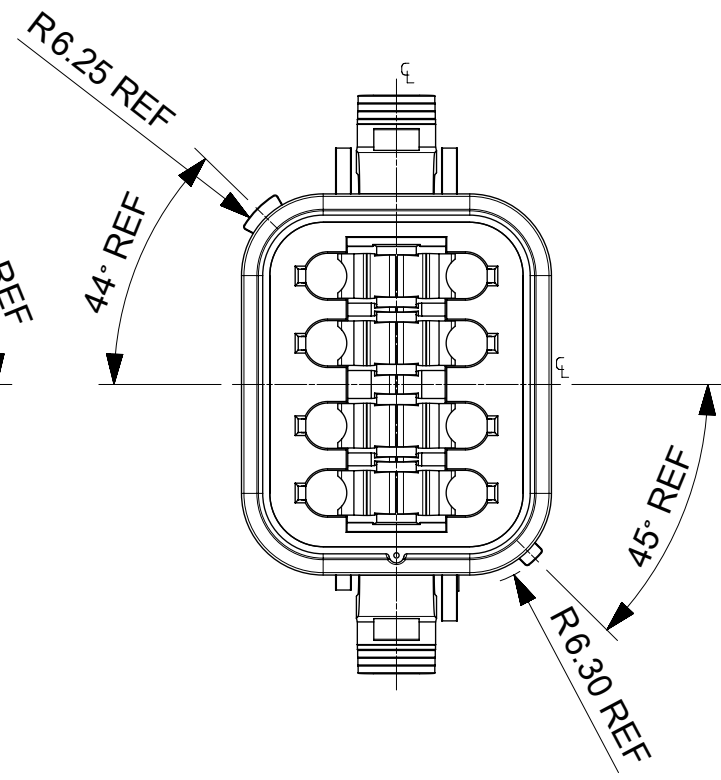
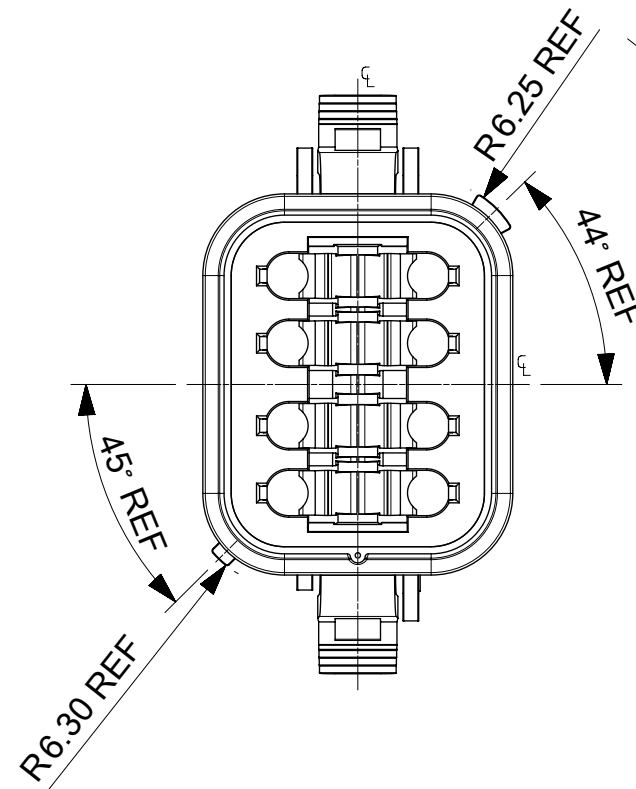
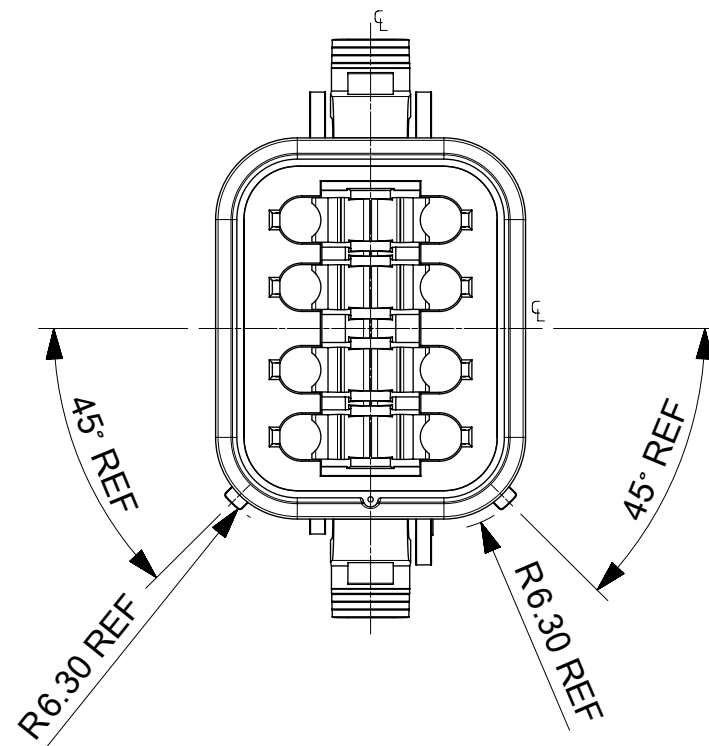
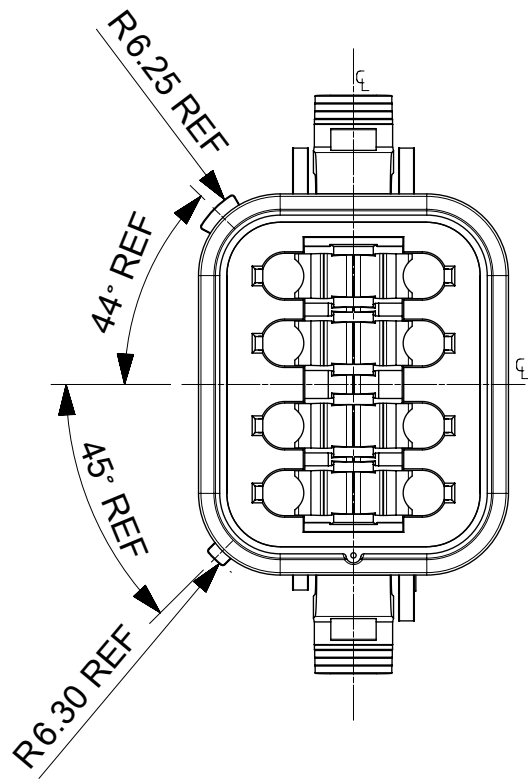
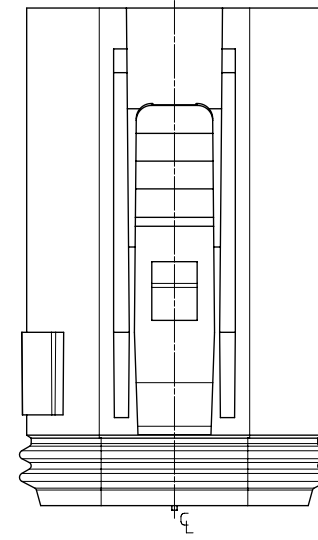
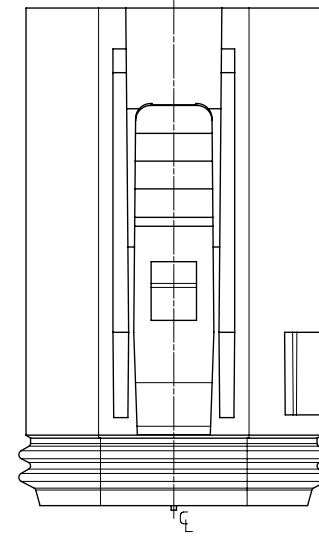
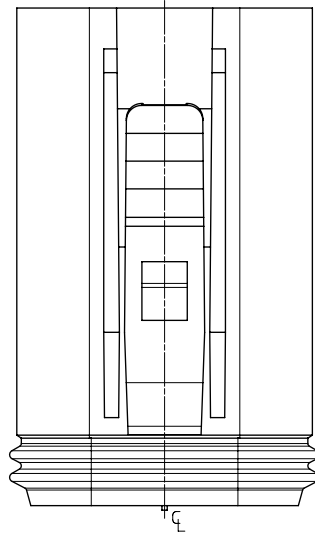
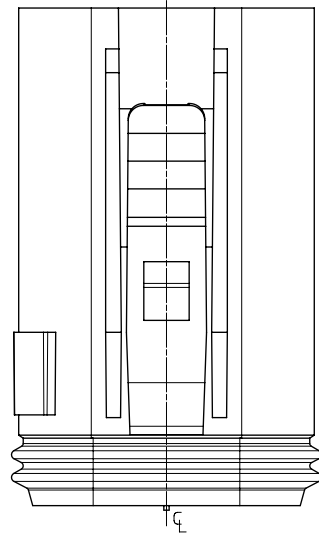

NOTES:
1. SEE SHEETS 6 & 7 FOR UNSPECIFIED NOTES & DIMENSIONS

THIS DRAWING CONTAINS INFORMATION THAT IS PROPRIETARY TO MOLEX ELECTRONIC TECHNOLOGIES, LLC AND SHOULD NOT BE USED WITHOUT WRITTEN PERMISSION													
QUALITY SYMBOLS		GENERAL TOLERANCES (UNLESS SPECIFIED)				DIMENSION UNITS		SCALE					
▽A	= 0	ANGULAR TOL ± 2.0 °				MM		2:1					
▽E	= 0	4 PLACES ±				DRWN BY		DATE		8CCT ML-XT CV CONNECTOR SYSTEM			
▽F	= 0	3 PLACES ±				JFLETCHER		2016/01/05					
▽B	= 0	2 PLACES ± 0.1				CHK'D BY		DATE		PRODUCT CUSTOMER DRAWING			
▽C	= 0	1 PLACE ± 0.2				FDUGGAN		2016/01/12					
▽	= 0	0 PLACES ±				APPR BY		DATE		SERIES: 93443 MATERIAL NUMBER: SEE NOTES CUSTOMER: GENERAL MARKET			
⊠	= 0	DRAFT WHERE APPLICABLE MUST REMAIN WITHIN DIMENSIONS				JDWALLACE		2016/01/14					
■	= 0	SEE LONG TEXT				DRAWING SIZE		THIRD ANGLE PROJECTION		DOCUMENT NUMBER: 934430050 DOC TYPE: PSD DOC PART: 000 SHEET NUMBER: 8 OF 9			
▽	= 0	EC NO: 111526		A1		A3							
RELEASE STATUS		P1		RELEASE DATE		06.06.2017		08:12:51					

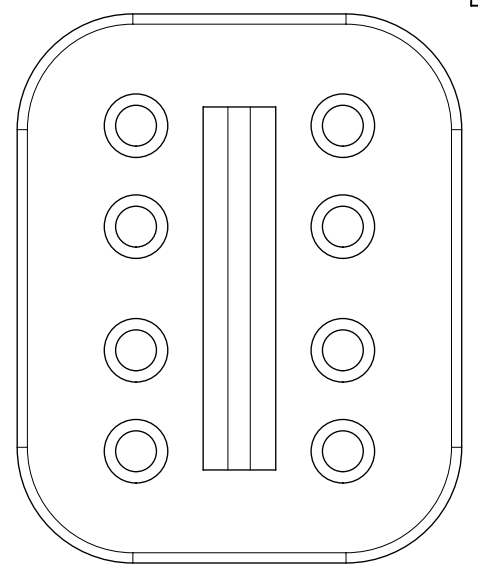
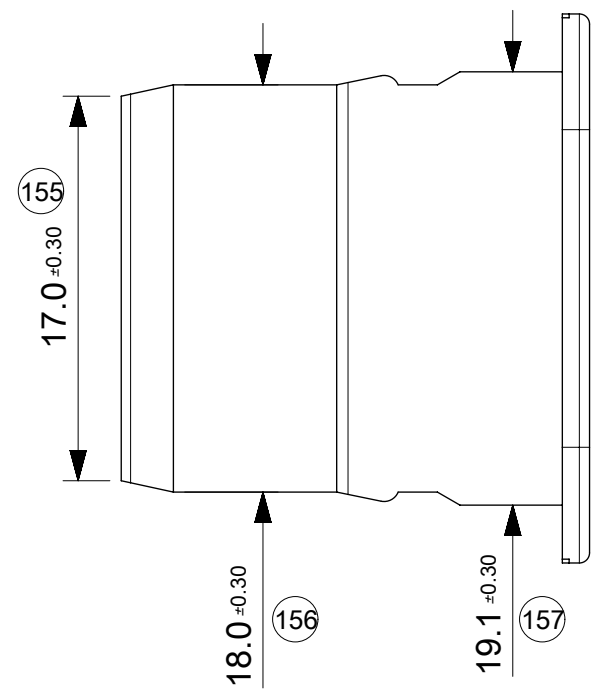
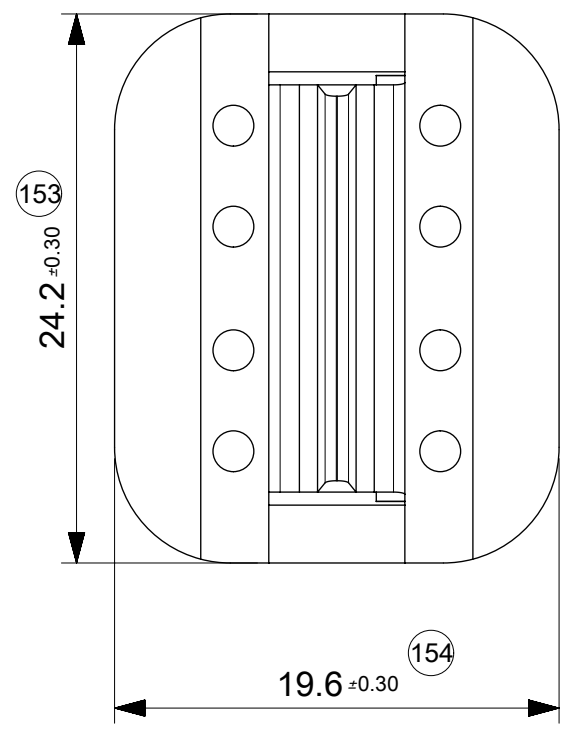
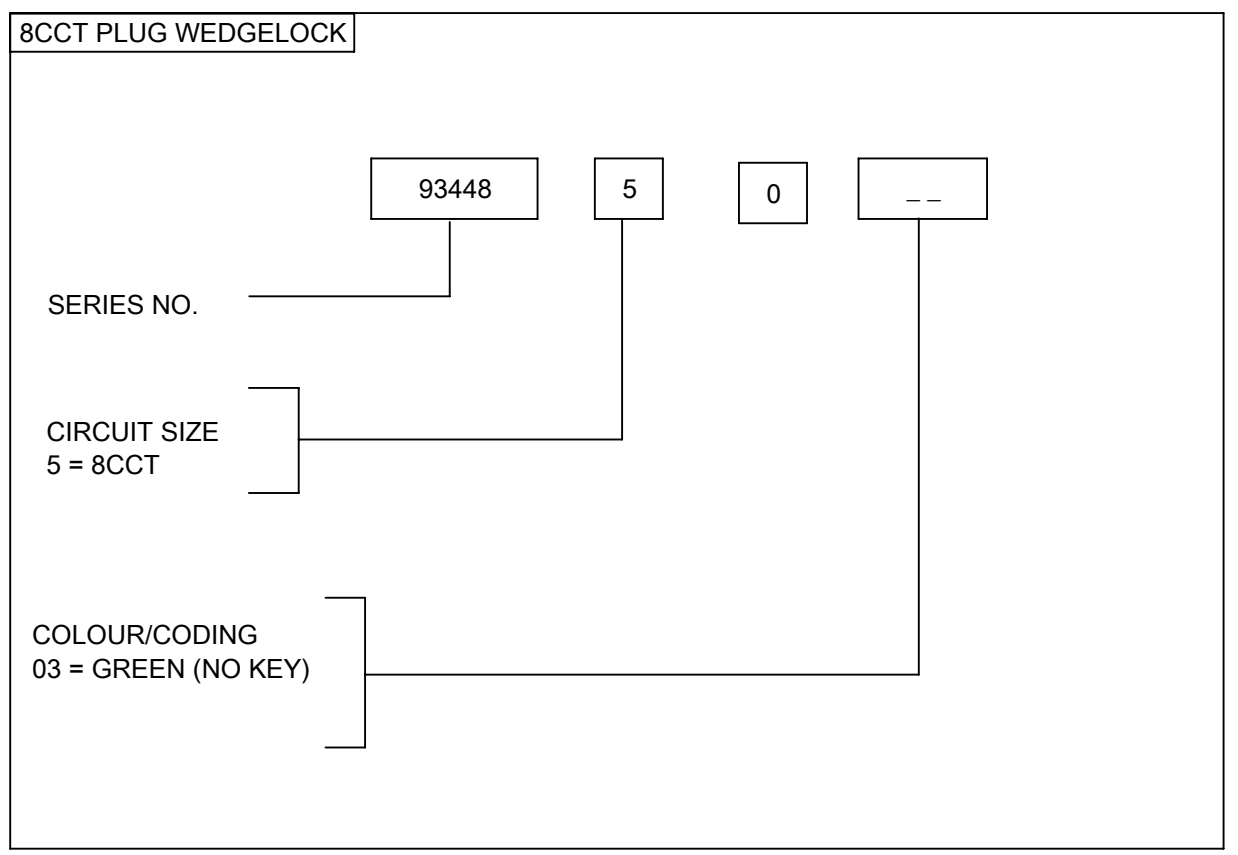
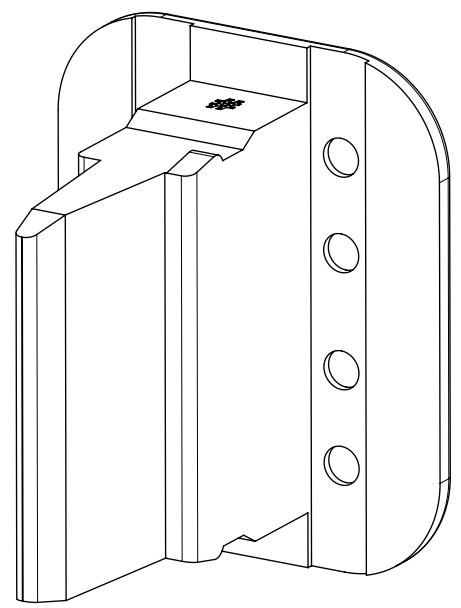
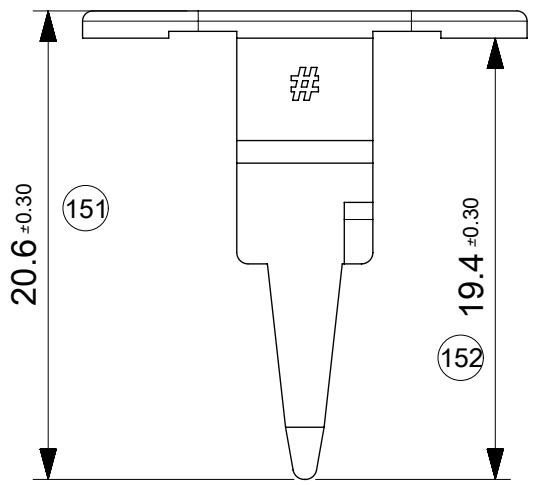

NOTES:
 1. MATERIAL: NYLON, 30% GLASS FILLED
 INSPECTION NUMBERS 151 - 200 USED FOR SHEET 9.
 LAST INSPECTION NUMBER 157

QUALITY SYMBOLS ▽A = 0 ▽E = 0 ▽F = 0 ▼ = 0 ▽C = 0 ⊠ = 0 ■ = 0 ▽ = 0	THIS DRAWING CONTAINS INFORMATION THAT IS PROPRIETARY TO MOLEX ELECTRONIC TECHNOLOGIES, LLC AND SHOULD NOT BE USED WITHOUT WRITTEN PERMISSION											
	EC NO: 111526 DRWN: JFLETCHER CHK'D: FDUGGAN APPR: JDWALLACE	2016/11/16 2016/11/18 2017/06/06	GENERAL TOLERANCES (UNLESS SPECIFIED)		DIMENSION UNITS	SCALE						
			ANGULAR TOL ± 2.0 °		MM	3:1						
			4 PLACES ±	DRWN BY		DATE		8CCT ML-XT CV CONNECTOR SYSTEM				
			3 PLACES ±	JFLETCHER		2016/01/05						
			2 PLACES ± 0.1	CHK'D BY		DATE		PRODUCT CUSTOMER DRAWING				
	1 PLACE ± 0.2	FDUGGAN		2016/01/12								
	0 PLACES ±	APPR BY		DATE		SERIES	MATERIAL NUMBER	CUSTOMER				
	DRAFT WHERE APPLICABLE MUST REMAIN WITHIN DIMENSIONS	JDWALLACE		2016/01/14		93443	SEE NOTES	GENERAL MARKET				
		DRAWING SIZE		THIRD ANGLE PROJECTION		DOCUMENT NUMBER		DOC TYPE	DOC PART	SHEET NUMBER		
	A3				934430050		PSD	000	9 OF 9			