

NOTES :

- ① APPLICABLE TERMINAL : SERIES 56134,59370
- ② MATE WITH : SERIES 55917,55959,501845
- ③ APPLY FOR (CIRCUIT/2)=EVEN
- ④ MATERIAL NO.

**51353-\*\*1\***

CIRCUIT SIZE      COLOR

NATURAL(WHITE) 0

- ⑤ LOCK SIDE CKT.NO. DIDN'T INDICATED 8~14CKT, INDICATE 16~40CKT.
- ⑥ MATERIAL : 66 NYLON, UL94V-0

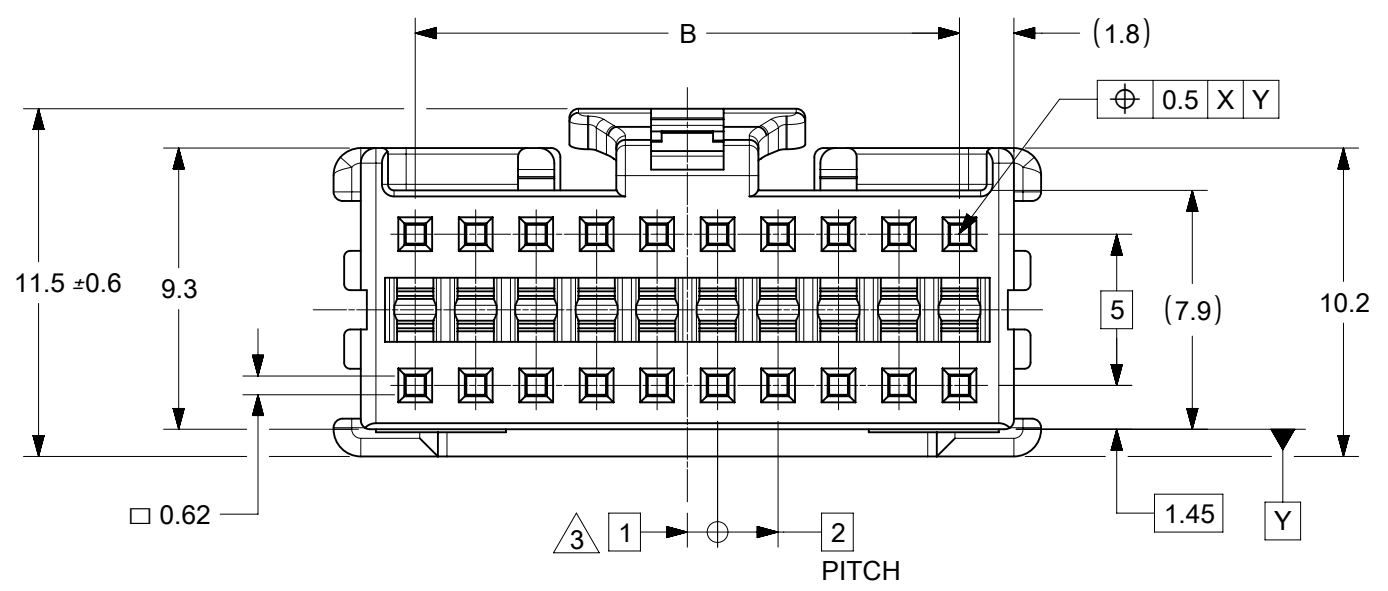
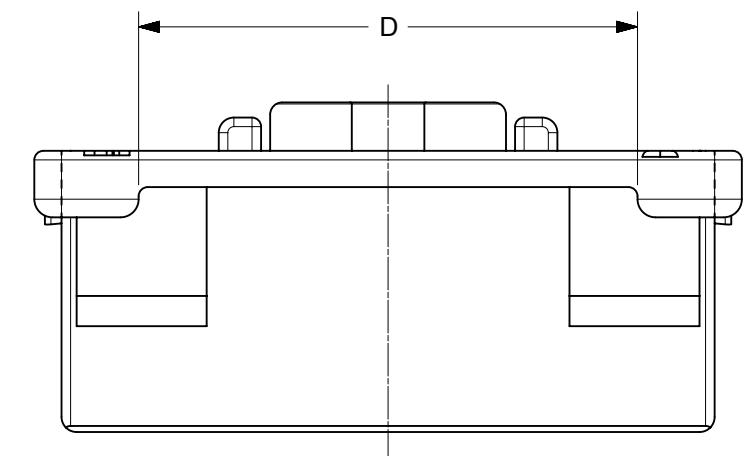
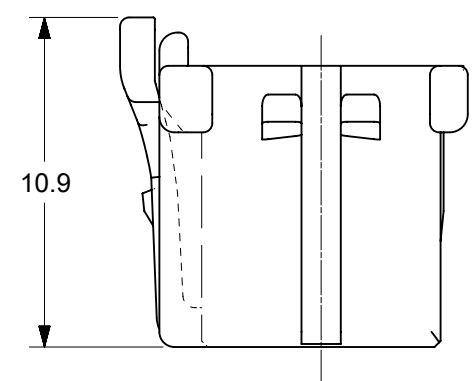
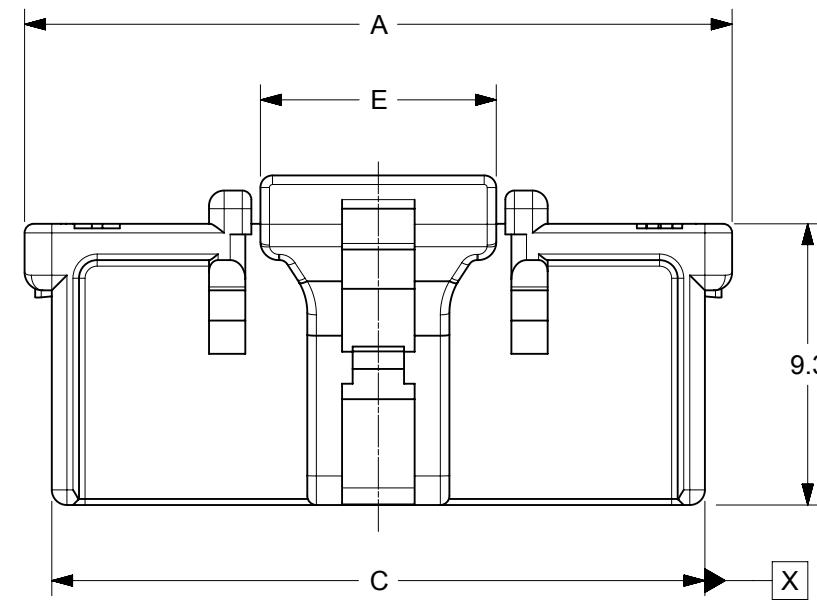

THIS DRAWING CONTAINS INFORMATION THAT IS PROPRIETARY TO MOLEX ELECTRONIC TECHNOLOGIES, LLC AND SHOULD NOT BE USED WITHOUT WRITTEN PERMISSION													
DIMENSION UNITS	SCALE	CURRENT REV DESC: REMASTERED IN ECTR											
mm		<b>molex</b>											
GENERAL TOLERANCES (UNLESS SPECIFIED)		MICROCLASP 2.0 W-B CONN. DUAL ROW RCPT HSG											
ANGULAR TOL	± 3.0°	PRODUCT CUSTOMER DRAWING											
4 PLACES	± 0.0	EC NO: 632022	2020/01/13	DOCUMENT NUMBER						DOC TYPE	DOC PART	REVISION	
3 PLACES	± 0.0	DRWN: SS06	2020/02/13										
2 PLACES	± 0.2	CHK'D: SS06	2020/02/14	SD-51353-003						PSD	001	G	
1 PLACE	± 0.2	APPR: ISHWARG	2020/02/14										
0 PLACES	± 0.2	INITIAL REVISION:		MATERIAL NUMBER						CUSTOMER		SHEET NUMBER	
		DRWN: YMAEDA	2007/06/18										
DRAFT WHERE APPLICABLE MUST REMAIN WITHIN DIMENSIONS		THIRD ANGLE PROJECTION	DRAWING	SERIES	SEE TABLE		GENERAL MARKET		1 OF 2				
			B-SIZE	51353									

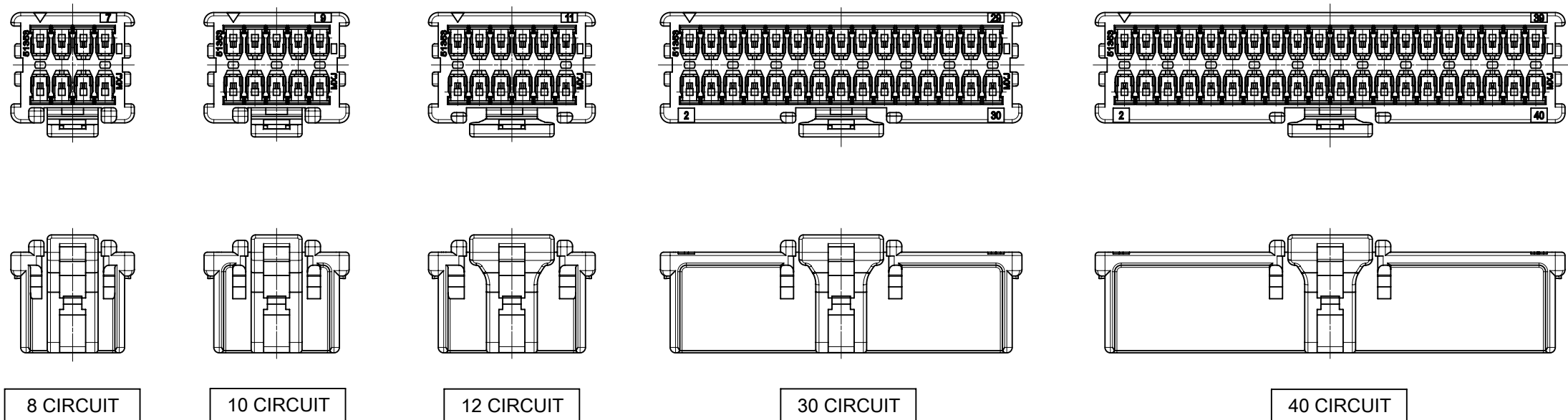

VIEW OF 8.10.12.30.40 CIRCUIT  
(2:1)

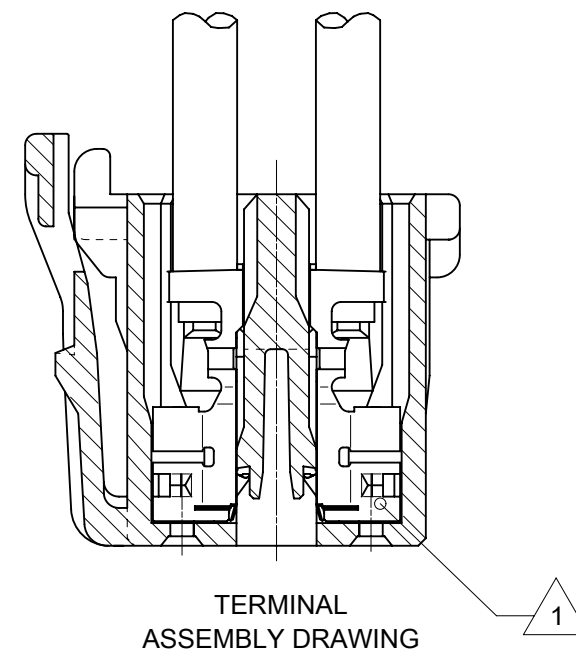

TERMINAL  
ASSEMBLY DRAWING

40	51353-4010	43.4	38	41.6	36.5	7.8
38	51353-3810	41.4	36	39.6	34.5	7.8
36	51353-3610	39.4	34	37.6	32.5	7.8
34	51353-3410	37.4	32	35.6	30.5	7.8
32	51353-3210	35.4	30	33.6	28.5	7.8
30	51353-3010	33.4	28	31.6	26.5	7.8
28	51353-2810	31.4	26	29.6	24.5	7.8
26	51353-2610	29.4	24	27.6	22.5	7.8
24	51353-2410	27.4	22	25.6	20.5	7.8
22	51353-2210	25.4	20	23.6	18.5	7.8
20	51353-2010	23.4	18	21.6	16.5	7.8
18	51353-1810	21.4	16	19.6	14.5	7.8
16	51353-1610	19.4	14	17.6	12.5	7.8
14	51353-1410	17.4	12	15.6	10.5	7.8
12	51353-1210	15.4	10	13.6	8.5	7.8
10	51353-1010	13.4	8	11.6	6.5	4.7
8	51353-0810	11.4	6	9.6	4.5	4.7
CKT.	TRAY PACKAGE	A	B	C	D	E
	ORDER NO.					

DIMENSION UNITS		SCALE	CURRENT REV DESC: REMASTERED IN ECTR		
mm					
GENERAL TOLERANCES (UNLESS SPECIFIED)					
ANGULAR TOL		± 3.0°	EC NO: 632022		
4 PLACES		± 0.0	DRWN: SS06 2020/01/13		
3 PLACES		± 0.0	CHK'D: SS06 2020/02/13		
2 PLACES		± 0.2	APPR: ISHWARG 2020/02/14		
1 PLACE		± 0.2	INITIAL REVISION:		
0 PLACES		± 0.2	DRWN: YMAEDA 2007/06/18		
			APPR: NUKITA 2015/04/10		
DRAFT WHERE APPLICABLE MUST REMAIN WITHIN DIMENSIONS		THIRD ANGLE PROJECTION	DRAWING	SERIES	MATERIAL NUMBER
			B-SIZE	51353	SEE SHEET 1
			CUSTOMER	SHEET NUMBER	
			GENERAL MARKET	2 OF 2	

**molex**

MICROCLASP 2.0 W-B CONN.  
DUAL ROW RCPT HSG

PRODUCT CUSTOMER DRAWING

DOCUMENT NUMBER	DOC TYPE	DOC PART	REVISION
SD-51353-003	PSD	001	G