

NOTES:

1. MATERIAL:
 - A) ADAPTER PLATE : COLD ROLLED STEEL (CRS)
 - B) ADAPTER HOUSING : POLYBUTYLENE TEREPHTHALATE (PBT)
 - C) PUSH FASTENER : NYLON (NYL)
2. FINISH:
 - ADAPTER PLATE : BLACK POWDER COAT.
3. ACCOMODATES 3 DUPLEX SC ADAPTERS PER PLATE.
4. ASSEMBLY IS PACKAGED INDIVIDUALLY IN A BAG.
5. DUST CAPS ARE NOT SHOWN.

PART NUMBER CHART			
MPN NO.	SAP NO.	DESCRIPTION	ADAPTER P/N
AFR-00360	180600138	ADAPT PLATE 6F DSC MM OM1/OM2 BEIGE	203-465-0L
AFR-00358	180600136	ADAPT PLATE 6F DSC SM OS1/2 BLUE	203-475-BL
AFR-00372	180600150	ADAPT PLATE 6F DSC MM OM3/OM4 AQ	203-465-AQ
AFR-00500	180600246	ADAPT PLATE 6F DSC MM OM4 EV	203-519-EV
AFR-00360-I	180600270	ADAPT PLATE 6F DSC MM OM1/OM2 BEIGE - IN	203-465-0L
AFR-00358-I	180600271	ADAPT PLATE 6F DSC SM OS1/2 BLUE - IN	203-475-BL
AFR-00372-I	180600272	ADAPT PLATE 6F DSC MM OM3/OM4 AQUA - IN	203-465-AQ
AFR-00500-I	180600273	ADAPT PLATE 6F DSC MM OM4 EV - IN	203-519-EV

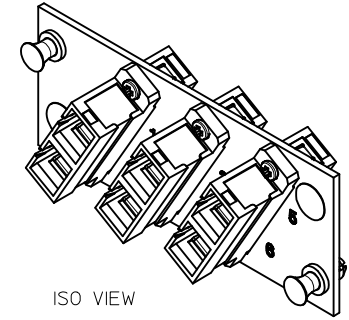

ENTER DESCRIPTION EC NO: MTS2016-0035 DRW: JUKUMAR 2015/12/16 CHK: D:RCG 2015/12/16 APPR: RCG 2016/01/27	QUALITY SYMBOLS F _A =0 F _B =0 F _C =0	GENERAL TOLERANCES (UNLESS SPECIFIED)		DIMENSION STYLE	SCALE	DESIGN UNITS	THIRD ANGLE PROJECTION	
				MM/IN	1:1	METRIC		
				mm INCH	DRAWN BY DATE		TITLE	
				4 PLACES ± --- ± ---	PS03 2009/06/30		ADAPT PLATE 6F DSC	
C4 REV	DESCRIPTION REV	DRAFT WHERE APPLICABLE MUST REMAIN WITHIN DIMENSIONS		CHECKED BY DATE	<div style="text-align: center; font-size: 2em; font-weight: bold;">molex</div> DOCUMENT NO. SD-18060-038 SHEET NO. 1 OF 1			
				JKUMAR 2009/06/30				
				1 PLACE ± 0.51 ± ---	APPROVED BY DATE			
				0 PLACE ± --- ± ---	JKUMAR 2009/06/30			
		ANGULAR ± --- °	MATERIAL NO.		THIS DRAWING CONTAINS INFORMATION THAT IS PROPRIETARY TO MOLEX INCORPORATED AND SHOULD NOT BE USED WITHOUT WRITTEN PERMISSION			
			SEE CHART					