

DATA SHEET

Full Size Stainless Steel Float Switches
with Bracket

MSB5600 Series

The bracket mounted MSB5600 Series liquid level float switches have a stainless steel stem and float. These switches are ideal for sumps and bilges where durability is required.

Provided with extended length leads enclosed in Teflon tubing for outdoor, submersible, or remote tank level detection, and carries CE approval.

Industries

- Marine
- Food equipment

Materials

- Stem and Float: 316 stainless steel

Specifications

- Mounting: bracket
- Max. temperature: 392°F / 200°C
- Max. pressure: 200 psi haz. loc., 750 psi standard loc.
- Float diameter: 2.05"

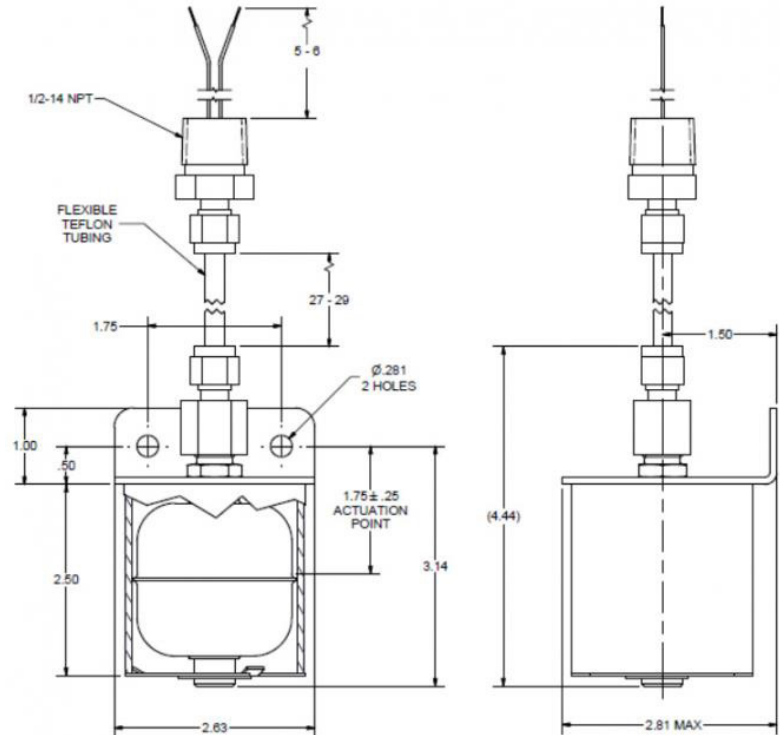

Custom Configurations

Contact us directly
for custom solutions.
Email: info@madisonco.com

Part Number	Minimum Media SG	Electrical Ratings	Lead Wires	Switch Rating	Approvals
MSB5600	0.63	240V AC, 0.40A; 120V AC, 1.0A; 120V DC, 0.40A; 24V DC, 1.0A	72", 22 AWG, Teflon insulated, enclosed in 1/4" OD Teflon tubing	60 watt, SPST	CE, NSF

NOTE: Other fittings and voltages are available. [Contact us](#) to discuss your application.



Level Switch Electrical Considerations and Reed Switch Protection

When using Madison level switches, it is important to consider the application’s electrical parameters. Our level switches utilize reed switch technology, which are glass encapsulated, magnetically actuated switches. Madison generally provides electrical ratings for resistive loads; however, where the maximum current of the load permits, the switches are capable of controlling devices such as motors, solenoids or coils that produce capacitive or inductive electrical loads. Where possible, Madison recommends the use of general-purpose/isolation relays or controllers to protect the switch.

Protect your level switch: Protection Techniques and Common Failure Modes

Reed Switch protection is the most successful method of increasing the performance and life of your level sensor. Since every application varies, it is important to understand your protection options. The life of the reed switch is typically 1 million cycles, within rated load conditions. The table below is a guide to suggested protection techniques and common failure modes associated with each load type.

Load	Load Example	Protection	Diagram	Common Failure Modes	Failure Mode Description
Resistive (DC)	Indicator Lamp, Heaters	Current Limiting Resistor	A	In-rush Current (Switching)	In-rush current exceeds rating and welds switch closed
				Over-Current (Carry)	Carry-current exceeds rating and switch welds or burns open like a fuse
Inductive & Capacitive (DC)	Relay Coil, Solenoids, Motor	Reversing Diode	B	Over-Voltage (Arcing)	Voltage arcing during switching welds contacts closed
Inductive & Capacitive (AC or DC)		Resistor & Capacitor Network	C		
Resistive, Inductive & Capacitive (AC or DC)	Indicator Lamp, Heaters, Relay Coil, Solenoids, Motor	Varistor or MOV	D	Over-Voltage (Arcing)	Transients voltage spikes exceed breakdown voltage and weld switch closed

Capacitive Load

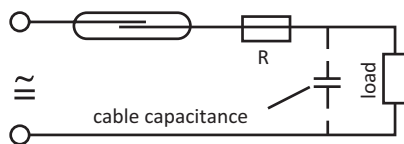

Diagram A: Current Limiting Resistor

Inductive Load

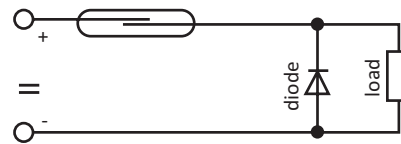

Diagram B: Reversing Diode

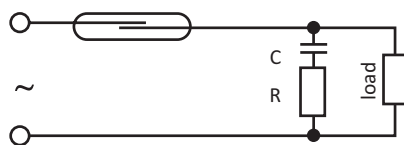

Diagram C: RC Network

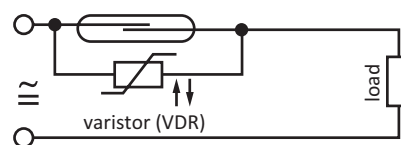

Diagram D: Varistor or MOV

For DC circuits: Insert a 1N4004 diode across the load (i.e.: relay coil) with the cathode end (marked with circular line) connected toward the positive side. This way the diode conducts only when the field collapses. General rule is to use a diode with a voltage rating at least three times the circuit voltage. A 1N4004 has a rating of 1 amp continuous, 30 amp surge, 400V max. Refer to diagram B.

For typical 120V AC circuits: Insert a 50 to 100 ohm, 1/2 watt Resistor in series with a .1 micro farad 400 to 600 volt capacitor across the switch. The capacitor is a high impedance to 60 hertz, but is essentially a short circuit to high frequencies of generated voltages. Alternately, a varistor V130LA10A by itself across the switch will also work for 120V AC. Refer to diagram D.



Madison Company | Sensing Solutions since 1959

27 Business Park Drive
Branford, CT 06405 USA

Toll-Free: 800.466.5383
Outside the USA: +1.203.488.4477

Made In The USA
www.madisonsensors.com