

DATA SHEET

High Pressure Inline Flow Switch

FS8000 Series

Madison

The robust, FS8000 inline flow switch is the pinnacle of reliability and performance in high-pressure applications. Engineered to resist clogging and deliver reliable consistent switching, the FS8000 showcases innovation through its one-piece magnetic Ryton piston. Tailored for high-pressure applications in industrial cleaning equipment and cooling systems, it embodies the perfect synergy of straightforward design and unwavering operational dependability for discerning engineers. Low pressure drop over the sensing range makes this the ideal solution for most applications. Reliable sensing for critical applications.



Wetted Materials

- Housing/Body: 316 Stainless Steel
- Piston: Ryton® R4
- Spring: 302 Stainless Steel
- O-Ring: Viton
- Epoxy

Specifications

- Fitting type: 3/8" NPT or 3/8" Compression Fitting
- Flow Switch Points: 0.10 - 3.0 GPM
- Set Point Accuracy: +/- 10%
- Operating temperature: -20° to 275°F
- Max. pressure: 1500 psi
- Switch rating: 20 watt SPST, 120VAC/VDC, N.O.
- Recommended Filtration: 100 micron
- Approvals: UL recognition (pending)

Part #: FS8000-____ (select suffix below)

Flow Setting (GPM)	3/8" NPT Male	3/8" Compression
0.10	10001	20001
0.15	10002	20002
0.25	10003	20003
0.50	10004	20004
0.75	10005	20005
1.00	10006	20006
1.50	10007	20007
2.00	10008	20008
2.50	10009	20009
3.00	10010	20010

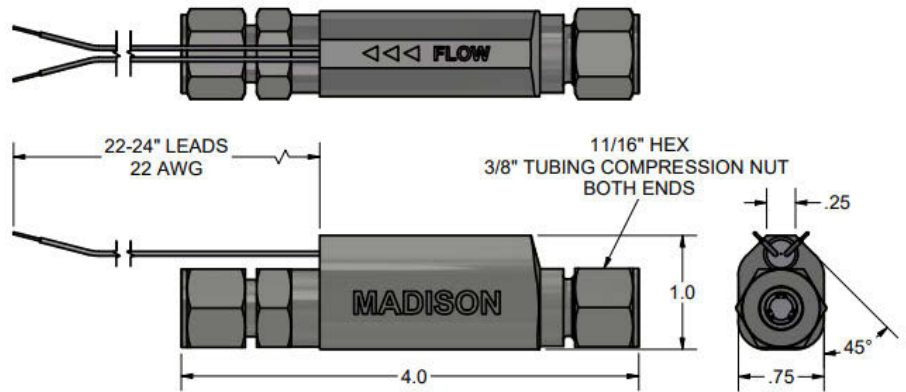
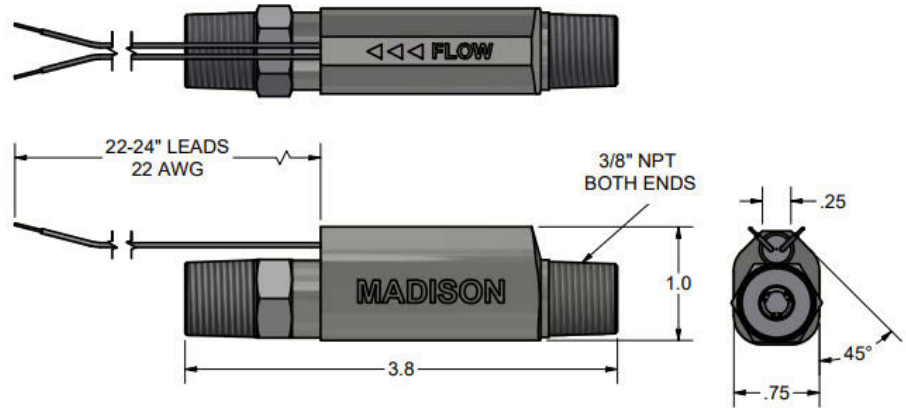

Pressure Drop vs. Flow Rate

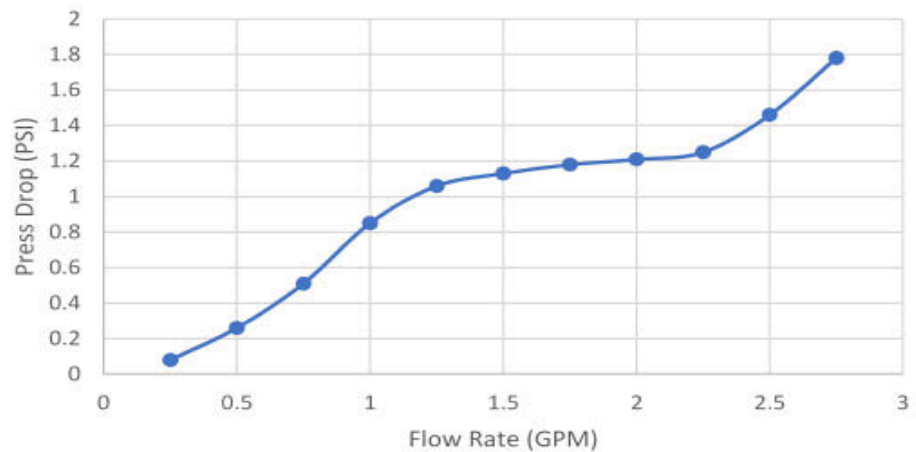

Custom Configurations

Contact us directly for custom solutions.
Email: info@madisonco.com



Flow Switch Electrical Considerations and Reed Switch Protection

When using Madison flow switches, it is important to consider the application’s electrical parameters. Our flow switches utilize reed switch technology, which are glass encapsulated, magnetically actuated switches. Madison generally provides electrical ratings for resistive loads; however, where the maximum current of the load permits, the switches are capable of controlling devices such as motors, solenoids or coils that produce capacitive or inductive electrical loads. Where possible, Madison recommends the use of general-purpose/isolation relays or controllers to protect the switch.

Protect your flow switch: Protection Techniques and Common Failure Modes

Reed Switch protection is the most successful method of increasing the performance and life of your level sensor. Since every application varies, it is important to understand your protection options. The life of the reed switch is typically 1 million cycles, within rated load conditions. The table below is a guide to suggested protection techniques and common failure modes associated with each load type.

Load	Load Example	Protection	Diagram	Common Failure Modes	Failure Mode Description
Resistive (DC)	Indicator Lamp, Heaters	Current Limiting Resistor	A	In-rush Current (Switching)	In-rush current exceeds rating and welds switch closed
				Over-Current (Carry)	Carry-current exceeds rating and switch welds or burns open like a fuse
Inductive & Capacitive (DC)	Relay Coil, Solenoids, Motor	Reversing Diode	B	Over-Voltage (Arcing)	Voltage arcing during switching welds contacts closed
Inductive & Capacitive (AC or DC)		Resistor & Capacitor Network	C		
Resistive, Inductive & Capacitive (AC or DC)	Indicator Lamp, Heaters, Relay Coil, Solenoids, Motor	Varistor or MOV	D	Over-Voltage (Arcing)	Transients voltage spikes exceed breakdown voltage and weld switch closed

Capacitive Load

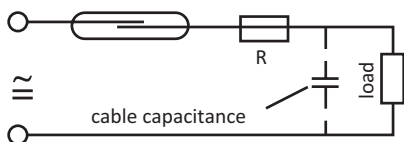

Diagram A: Current Limiting Resistor

Inductive Load

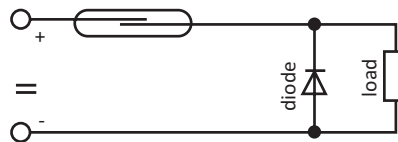

Diagram B: Reversing Diode

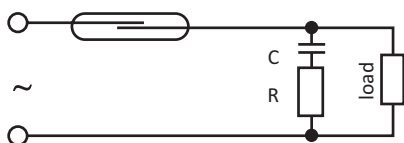

Diagram C: RC Network

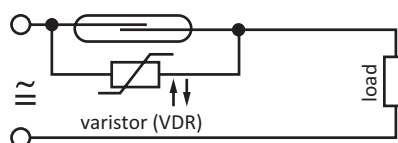

Diagram D: Varistor or MOV

For DC circuits: Insert a 1N4004 diode across the load (i.e.: relay coil) with the cathode end (marked with circular line) connected toward the positive side. This way the diode conducts only when the field collapses. General rule is to use a diode with a voltage rating at least three times the circuit voltage. A 1N4004 has a rating of 1 amp continuous, 30 amp surge, 400V max. Refer to diagram B.

For typical 120V AC circuits: Insert a 50 to 100 ohm, 1/2 watt Resistor in series with a .1 micro farad 400 to 600 volt capacitor across the switch. The capacitor is a high impedance to 60 hertz, but is essentially a short circuit to high frequencies of generated voltages. Alternately, a varistor V130LA10A by itself across the switch will also work for 120V AC. Refer to diagram D.



Madison Company | Sensing Solutions since 1959

27 Business Park Drive
Branford, CT 06405 USA

Toll-Free: 800.466.5383
Outside the USA: +1.203.488.4477

