

# MBS-STOOL-2

## Adjustable-Height School Stool with Wheels and Storage

### Product Specifications

|                               |   |
|-------------------------------|---|
| Item Number                   | MBS-STOOL-2   |
| Material                      | <b>Seat:</b> PP+ glass fiber<br><b>Frame and Legs:</b> Powder-coated steel<br><b>Storage Bin:</b> Polypropylene |
| Overall Dimensions            | 19.75" W x 19.75" D x 20" to 27" H  |
| Seat Height                   | 18" to 25" H (in 1" increments)   |
| Backrest Dimensions           | 9" W x 2" H   |
| Seat Dimensions               | 16.75" W x 16.5" D  |
| Removable Bin Dimensions      | 12.25" W x 16.75" D x 3" H  |
| Removable Bin Weight Capacity | 20 lbs. (when fully inserted)<br>5 lbs. (when pulled out on its track)  |
| Product Weight                | 17 lbs.   |
| Casters                       | 2" full-swivel, all casters include locking brakes which secure both the wheel and the swivel mechanism         |
| Additional Features           | Grab handle   |
| Weight Capacity               | 269 lbs.  |
| Maximum Stack Height          | 3 (bins must be removed for stacking)   |
| Shipping Method               | Ground  |
| Shipping Carton Dimensions    | 17.5" W x 17.5" D x 15.75" H  |
| Shipping Weight               | 19.25 lbs.  |
| Assembly Required             | Yes   |
| Chair Compliance              | ANSI/BIFMA  |

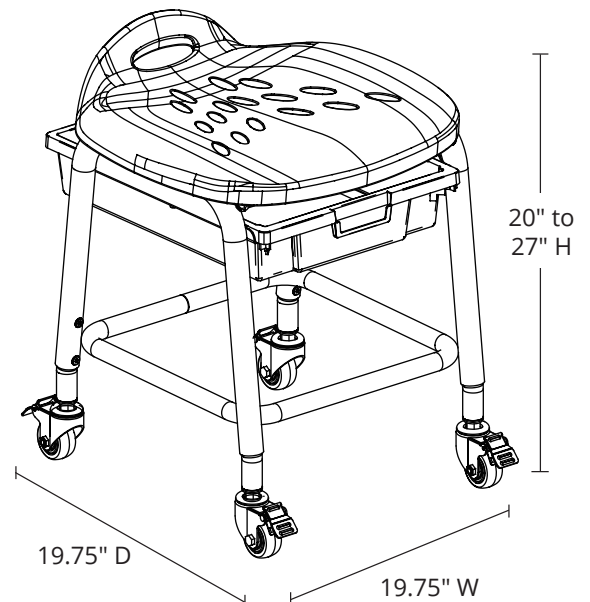

**WARNING:** Do not stand on the stools. Do not stack more than 3 high.

To Order, Call Your  
Sales Representative or  
800-323-4656