



One Henkel Way
Rocky Hill, CT 06067-3910
Telephone: (860) 571-5100
FAX: (860) 571-5465

Product Description Sheet

Digital Syringe Dispensing System

Part # 97006

North American Equipment

PRODUCT DESCRIPTION

The Loctite® Digital Syringe Dispensing System accurately dispenses adhesives or other fluids, with viscosities ranging from water-thin to paste-like consistencies, for a variety of assembly and repair applications. This system is effective at delivering precise dots of adhesive in a timed mode, or can be used on demand for beads or potting, in a continuous mode. Typical applications are the assembly of electrical components, wire tacking, circuit board repair, and the locking of fasteners.

PRODUCT FEATURES

- Precision air pressure regulator for precise application of small dots
- Digital display of dispense pressure, 0-100 psi
- Digital timer display, for precise timer settings
- Vacuum suck-back feature to prevent dripping during idle time
- "Stand-up" design, requires minimal bench space
- Quick pressure setup feature
- Process monitoring – air pressure sensor detects $\pm 10\%$ variation from set pressure and alerts operator if detected.
- Operates in a timed or continuous mode

Bench Space Requirements

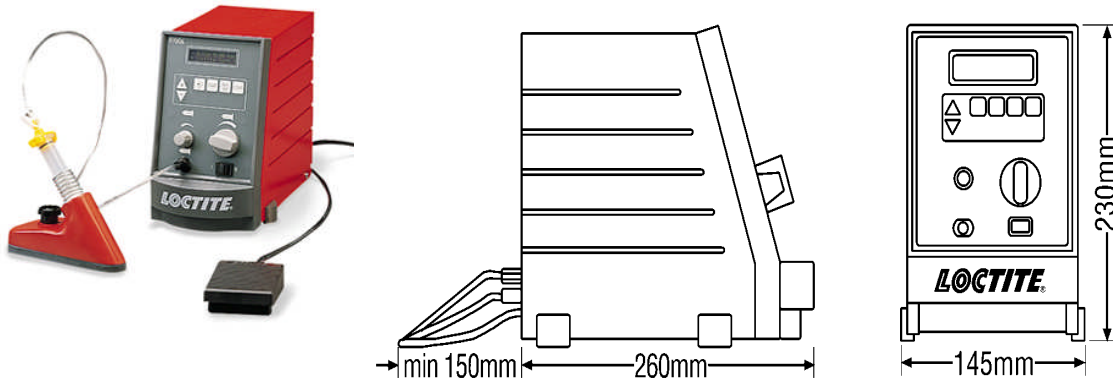

Technical Data

- Power Supply: 90-260 VAC; 47-63 Hz
- Air Supply: Min. 30 psi
- Pressure Regulator: 0-100 psi
- Dispense Time Range: 0.01-99.9 seconds
- Size: 5.7" W x 9" H x 10.2" D
- Weight: 6.17 lbs.

Required Parts (must be purchased separately)

- Syringe airline adapter 10 ml. (P/N 97208) or 30 ml. (P/N 97245)
- Syringe starter kit 10 ml. (P/N 97216) or 30 ml. (P/N 97294)

Parts Supplied

- Power Cord
- Footswitch
- Operation manual

Optional Accessories (purchased separately)

- 10 ml. clear syringe barrel kit P/N 97207
- 30 ml. clear syringe barrel kit P/N 97244
- 10 ml. black syringe barrel kit P/N 97263
- 30 ml. black syringe barrel kit P/N 97264
- Syringe filler kit for downloading adhesive from 300 ml. cartridges into 10 or 30 ml. syringes. P/N 97215
- Syringe stand for 10 & 30 ml. barrels P/N 984625
- Showcase needle variety kit P/N 98044

NOT FOR PRODUCT SPECIFICATIONS
PLEASE CONTACT LOCTITE CORPORATION FOR ASSISTANCE: 1- 800-LOCTITE (1-800-562-8483)

The data contained herein are furnished for information only and are believed to be reliable. We cannot assume responsibility for the results obtained by others over whose methods we have no control. It is the user's responsibility to determine suitability for the user's purpose of any production methods mentioned herein and to adopt such precautions as may be advisable for the protection of property and of persons against any hazards that may be involved in the handling and use thereof. In light of the foregoing, LOCTITE CORPORATION SPECIFICALLY DISCLAIMS ALL WARRANTIES EXPRESSED OR IMPLIED, INCLUDING WARRANTIES OF MERCHANTABILITY OR FITNESS FOR A PARTICULAR PURPOSE, ARISING FROM SALE OR USE OF LOCTITE CORPORATION'S PRODUCTS. LOCTITE CORPORATION SPECIFICALLY DISCLAIMS ANY LIABILITY FOR CONSEQUENTIAL OR INCIDENTAL DAMAGES OF ANY KIND, INCLUDING LOST PROFITS. The discussion herein of various processes or compositions is not to be interpreted as representation that they are free from domination of patents owned by others or as a license under any Loctite Corporation patents that may cover such processes or compositions. We recommend that each prospective user test his proposed application before repetitive use, using this data as a guide. This product may be covered by one or more United States or foreign patents or patent applications.