

Cmod S7 Reference Manual

The Digilent Cmod S7 is a small, 48-pin DIP form factor board built around a Xilinx Spartan 7 FPGA. 32 FPGA digital I/O signals, 2 FPGA analog input signals, an external power input rail, and ground are routed to 100-mil-spaced through-hole pins, making the Cmod S7 well suited for use with solderless breadboards. At just 0.7" by 3.05" inches, it can be loaded in a standard socket and used in embedded systems. The board also includes a programming ROM, clock source, USB programming and data transfer circuit, power supplies, LEDs, and buttons.

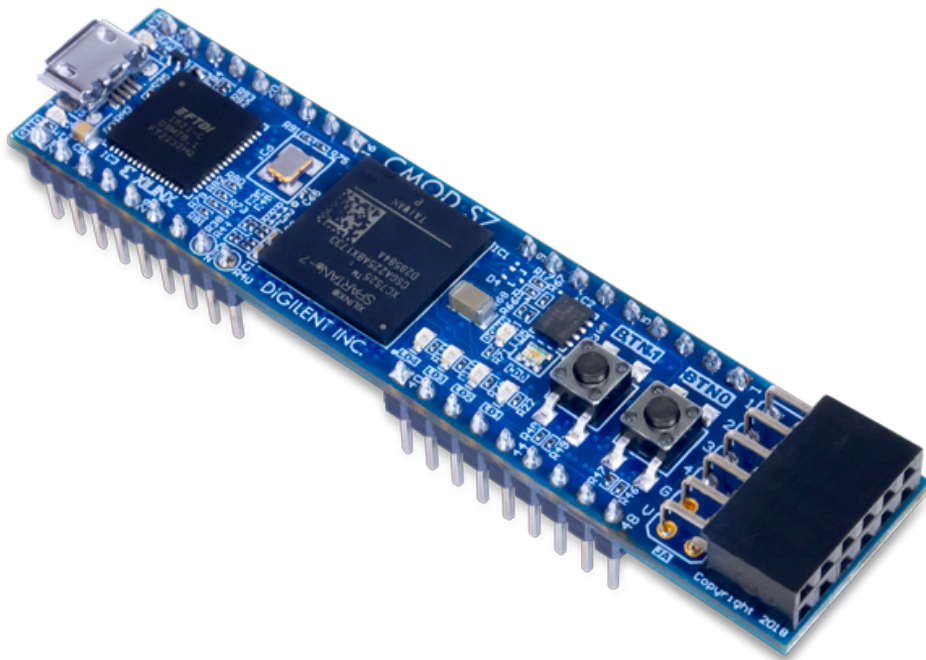

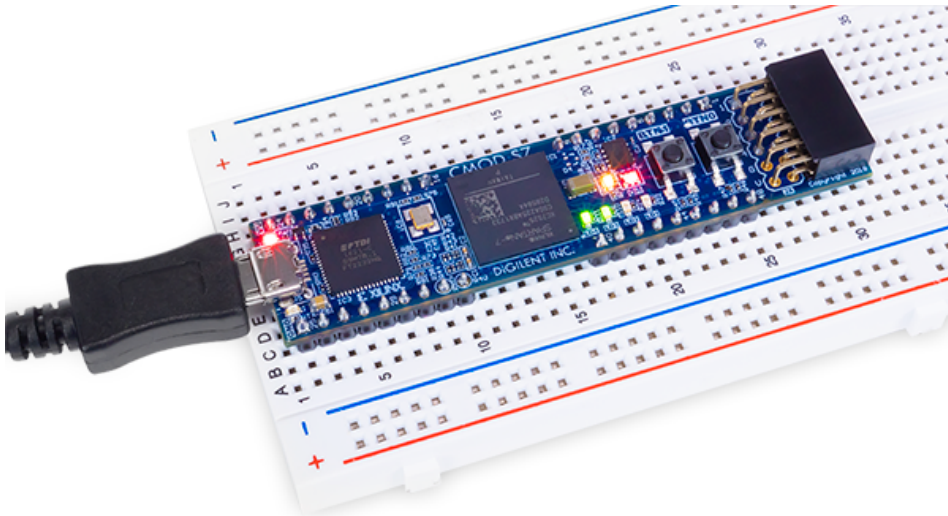

Features

- **Xilinx Spartan-7 FPGA (XC7S25-1CSGA225C)**
 - 3,650 slices containing four 6-input LUTs and 8 flip-flops
 - 1,620 Kbits of fast block RAM
 - 3 clock management tiles, each with a phase-locked loop and mixed-mode clock manager
 - 80 DSP slices
 - Internal clock speeds exceeding 450 MHz
 - On-chip analog-to-digital converter (XADC)
 - Programmable over JTAG and Quad-SPI Flash
- **Memory**
 - 4 MB Quad-SPI Flash
- **Power**
 - Powered from USB or 5V external supply connected to DIP pin 24
- **USB**
 - USB-JTAG programming circuitry
 - USB-UART bridge
- **Push-buttons and LEDs**
 - 2 Buttons
 - 4 LEDs
 - 1 RGB LED
- **Expansion Connectors**
 - 1 Pmod connector
 - 8 total FPGA I/O
 - 48-pin DIP form-factor header
 - 32 total FPGA I/O
 - 2 single-ended 0-3.3V analog inputs to XADC
 - 2 power pins

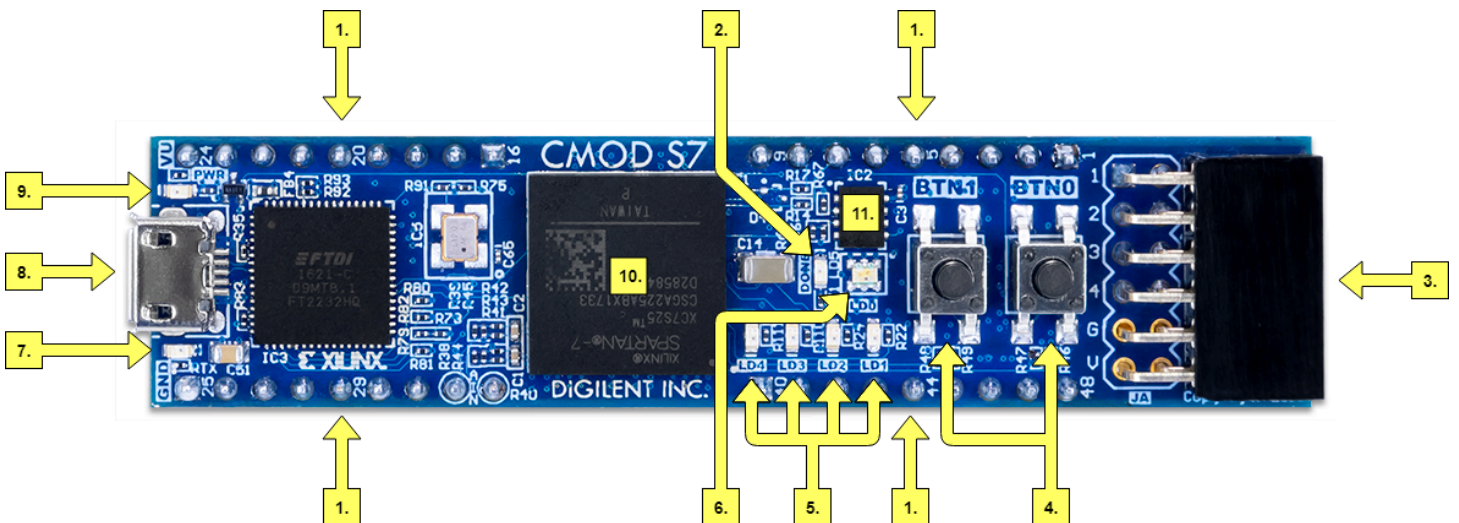

Callout	Description	Callout	Description
1	48-pin DIP form factor header	7	UART status LED
2	FPGA programming DONE LED	8	Shared USB JTAG/UART port
3	Pmod connector	9	Power good LED ()
4	User push buttons	10	Spartan-7 FPGA
5	User LEDs	11	SPI Flash
6	User tri-color LED		

Software Support

The Cmod S7 is fully compatible with the high-performance Vivado® Design Suite versions 2018.1 and newer. It is supported under the free WebPACK™ installation option, which does not require a license, so designs can be implemented at no additional cost. This free installation includes the ability to create MicroBlaze™ soft-core processor designs. Design resources, example projects, and tutorials are available for download at the Cmod S7 Resource Center (<https://digilent.com/reference/programmable-logic/cmod-s7/start>).

The Cmod S7 can be used with Vivado 2017.4, but WebPACK installations of this version of Vivado may not contain the device files for the specific Spartan-7 FPGA used on the Cmod S7. See this Xilinx Answer Record (<https://support.xilinx.com/s/article/70505>) for more information, and for a solution.

Functional Description

1 Power Supplies

The Cmod S7 uses a Linear Technologies LTC3569 triple output buck power regulator to generate the needed voltages for the onboard components. It is connected as shown in Figure 1.1. The characteristics of the outputs are shown in Table 1.1.

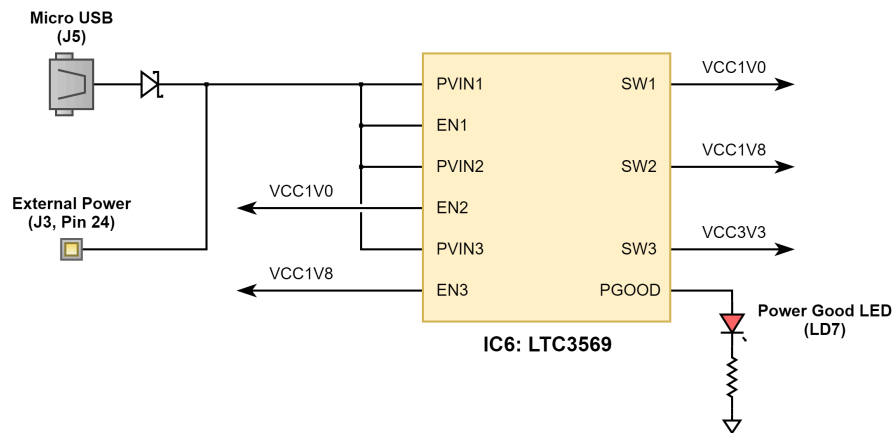

Figure 1.1 Power Supply

Supply	Circuits	Device	Maximum Current
3.3V	FPGA User I/O, USB Controller, Flash Memory, Pmod Connector, LEDs, Buttons	IC6: LTC3569	1.2A
1.8V	FPGA, USB Controller	IC6: LTC3569	0.6A
1.0V	FPGA Core and Block RAM	IC6: LTC3569	0.6A

Table 1.1 Power Rail Characteristics

1.1 Power Input Options

It is possible to power the Cmod S7 from either USB or from an external power supply attached to pins 24 and 25 of the DIP headers, labeled “VU” and “GND”, respectively. The required characteristics of a power source attached to either of these two options is outlined in Table 1.1.1.

Connector Type	Connector Label	Min/Rec/Max Voltage
USB	J5	Per USB Specification
DIP	J3 (Pin 24)	4.5/5.0/5.5

When the Cmod S7 is powered by the USB connector, the voltage from the USB device is driven onto the VU pin. This makes it possible to power an external circuit from the USB host in addition to the Cmod S7. The VU pin is driven via a schottky diode, so a small voltage drop will occur, but it should be assumed that the voltage present on VU will be close to 5V.

Warning: When a USB host is attached to the micro USB connector, the VU pin on the DIP headers (pin 24) is driven to the voltage being provided by the USB host (typically 4.5V-5.5V). To avoid risk of damage, any power source attached to the VU pin must be disconnected before a USB host is attached. Not taking this precaution can be particularly dangerous if the power source is a battery.

2 FPGA Configuration

After power-on, the Spartan-7 FPGA must be configured (or programmed) before it can perform any functions. The FPGA can be configured in one of two ways:

- A PC can use the Digilent USB-JTAG circuitry (port J5) to program the FPGA any time the power is on.
- A file stored in the nonvolatile serial (SPI) flash device can be transferred to the FPGA using the SPI port.

Figure 2.1 shows the different options available for configuring the FPGA.

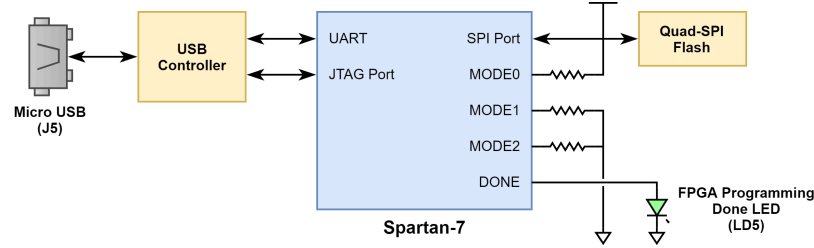

Figure 2.1 Configuration

The FPGA configuration data is stored in files called bitstreams that have the .bit file extension. The Vivado software from Xilinx can create bitstreams from VHDL, Verilog®, or block-level designs.

Bitstreams are stored in volatile memory cells within the FPGA. This data defines the FPGA's logic functions and circuit connections, and it remains valid until it is erased by removing board power, or by writing a new configuration file using the JTAG port.

A Spartan-7 25T bitstream is typically 9,935,224 bits. The time it takes to program the Cmod S7 can be decreased by compressing the bitstream before programming, and then allowing the FPGA to decompress the bitstream itself during configuration. Depending on design complexity, compression ratios of 10x can be achieved. Bitstream compression can be enabled within the Xilinx tools to occur during generation, and is enabled by default in Digilent's master XDC file for the Cmod S7. For more information on how to do this, consult the Xilinx documentation for the toolset being used.

After successful programming, the FPGA will cause the "DONE" LED to illuminate.

The following sections provide greater detail about programming the Cmod S7 using the different methods available.

2.1 JTAG Configuration

The Xilinx tools typically communicate with FPGAs using the Test Access Port and Boundary-Scan Architecture, commonly referred to as JTAG. During JTAG programming, a .bit file is transferred from the PC to the FPGA using the onboard Digilent USB-JTAG circuitry (port J5). JTAG programming can be performed any time after the Cmod S7 has been powered on. If the FPGA is already configured, then the existing configuration is overwritten with the bitstream being transferred over JTAG.

Programming the Cmod S7 with an uncompressed bitstream using the onboard USB-JTAG circuitry usually takes around 6 seconds. JTAG programming can be performed by Vivado's Hardware Manager.

2.2 Quad-SPI Configuration

Since the FPGA's memory on the Cmod S7 is volatile, it relies on the Quad-SPI flash memory to store the configuration between power cycles. This configuration mode is called Master SPI. The blank FPGA takes the role of master and reads the configuration file out of the flash device upon power-up. To that effect, a configuration file needs to first be written to the flash. When programming a non-volatile flash device, a bitstream file is transferred to the flash in a two-step process. First, the FPGA is programmed with a circuit that can program flash devices, and then data is transferred to the flash device via the FPGA circuit (this complexity is hidden from the user by the Xilinx tools). This is called indirect programming. After the flash device has been programmed, it will automatically configure the FPGA at any subsequent power-on event. Programming files stored in the flash device will remain until they are overwritten, regardless of power-cycle events.

Quad-SPI programming can be performed using Vivado's Hardware Manager.

3 Quad-SPI Flash

FPGA Configuration files can be written to the Quad-SPI Flash (Macronix part number MX25L3233F). The FPGA will automatically read a configuration file from this device at power on. A Spartan-7 25T configuration file requires 9,935,224 bits of memory, leaving about 69% of the flash device (or ~2.8 MB) available for user data. A common use for this extra memory is to store MicroBlaze programs too big to fit in the onboard block memory. These programs are then loaded and executed using a smaller bootloader program that can fit in the block memory. It is possible to automatically generate this bootloader, roll it into the bitstream, and then program the bitstream and large MicroBlaze program into the Quad SPI Flash using Xilinx SDK.

The contents of the memory can be manipulated by issuing certain commands on the SPI bus. The implementation of this protocol is outside the scope of this document. Xilinx's AXI Quad SPI IP core can be used to read/write the flash in a MicroBlaze design. Refer to Xilinx's product guide (<https://docs.xilinx.com/v/u/en-US/pg153-axi-quad-spi>) for this core to learn more about using it, or to Macronix's datasheet (<http://www.macronix.com/Lists/Datasheet/Attachments/6744/MX25L3233F;%203V;%2032Mb;%20v1.6.pdf>) for the flash device to learn how to implement a custom controller. All signals in the SPI bus are general-purpose user I/O pins after FPGA configuration and can be used like any other FPGA I/O.

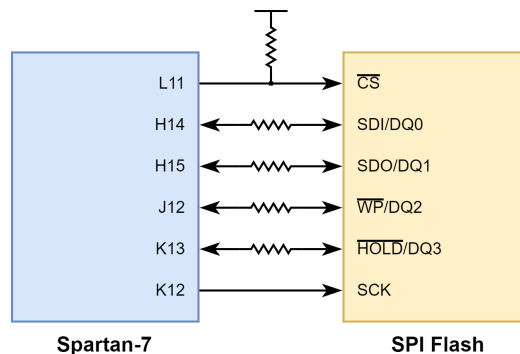

Figure 3.1 Flash Interface

4 Oscillators/Clocks

The Cmod S7 includes a 12 MHz crystal oscillator connected to pin M9 (an MRCC input on bank 14). This clock is intended to be used as a general purpose system clock. The clock can drive MMCMs to generate clocks of various frequencies and with known phase relationships that may be needed throughout a design. The 12 MHz input clock cannot directly drive a PLL because they have a minimum input frequency of 19 MHz. Some rules restrict which MMCMs and PLLs may be driven by the 12 MHz input clock. For a full description of these rules and of the capabilities of the Spartan-7 clocking resources, refer to [Xilinx UG472 \(https://docs.xilinx.com/v/u/en-US/ug472_7Series_Clocking\)](https://docs.xilinx.com/v/u/en-US/ug472_7Series_Clocking), titled “7 Series FPGAs Clocking Resources User Guide”.

Xilinx offers the Clocking Wizard IP core to help users generate the different clocks required for a specific design. This wizard will properly instantiate the needed MMCMs and PLLs based on the desired frequencies and phase relationships specified by the user. The wizard will then output an easy-to-use wrapper component around these clocking resources that can be inserted into the user’s design. The clocking wizard can be accessed from within the Vivado and IP Integrator tools.

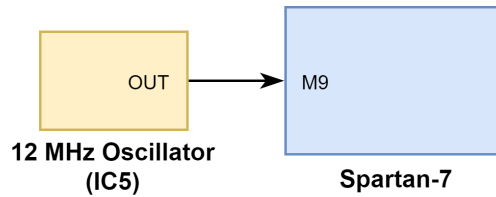

Figure 4.1 Clock Input

5 USB-UART Bridge (Serial Port)

The Cmod S7 includes an FTDI FT2232HQ USB-UART bridge (attached to Micro-USB connector J5) that allows the user to use PC applications to communicate with the board using standard Windows COM port commands. Free USB-COM drivers, available from [FTDI’s website \(https://www.ftdichip.com\)](https://www.ftdichip.com) under the “Virtual Com Port” or VCP heading, convert USB packets to UART/serial data. Serial port data is exchanged with the FPGA using a two-wire serial port (TXD/RXD). After the drivers are installed, I/O commands can be used from the PC directed to the COM port to produce serial data traffic on the K15 and L12 FPGA pins.

An onboard status LED (LD6) provides visual feedback on traffic flowing through the port.

The FT2232HQ is also used as the controller for the Digilent USB-JTAG circuitry, but the USB-UART and USB-JTAG functions behave entirely independent of one another. Programmers interested in using the UART functionality of the FT2232 within their designs do not need to worry about the JTAG circuitry interfering with the UART data transfers, and vice-versa. The combination of these two features into a single device allows the Cmod S7 to be programmed, communicated with via UART, and powered from a computer attached with a single Micro USB cable.

The connections between the FT2232HQ and the Spartan-7 are shown in Figure 5.1. Signal names that imply direction are from the point-of-view of the DTE (Data Terminal Equipment), in this case, a PC connected to the Micro USB port.

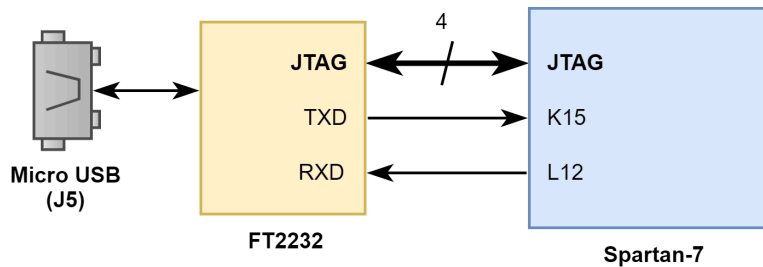

Figure 5.1 USB-UART Bridge

6 Basic I/O

The Cmod S7 includes one RGB LED, 4 individual LEDs, and 2 push buttons, as shown in Figure 6.1. The push buttons are connected to the FPGA via series resistors to prevent damage from inadvertent short circuits (a short circuit could occur if an FPGA pin assigned to a button was inadvertently defined as an output). The buttons are “momentary” switches that normally generate a low output when they are at rest, and a high output only when they are pressed.

The four individual high-efficiency LEDs are anode-connected to the FPGA via 330 Ohm resistors, so that they will turn on when a logic-high voltage is applied to their respective I/O pins. Additional LEDs that are not user-accessible indicate power-on, FPGA programming status, and USB-UART traffic.

The single RGB LED has three input signals that drive the cathodes of three smaller internal LEDs: one red, one blue, and one green. Driving the signal corresponding to one of these colors low will illuminate the internal LED. The RGB LED will emit a color dependent on the combination of internal LEDs that are currently being illuminated. For example, if the red and blue signals are driven low and green is driven high, the RGB LED will emit a purple color.

Note: Digilent strongly recommends the use of pulse-width modulation (PWM) when driving the RGB LED. Driving any of the signals to a steady logic '0' will result in the LED being illuminated at an uncomfortably bright level. This can be avoided by ensuring that none of the RGB signals are driven with more than a 50% duty cycle. Using PWM also greatly expands the potential color palette of the RGB LED. Individually adjusting the duty cycle of each color between 50% and 0% causes the different colors to be illuminated at different intensities, allowing virtually any color to be displayed.

Figure 6.1 shows how each of the LEDs and push buttons are connected to the Spartan-7.

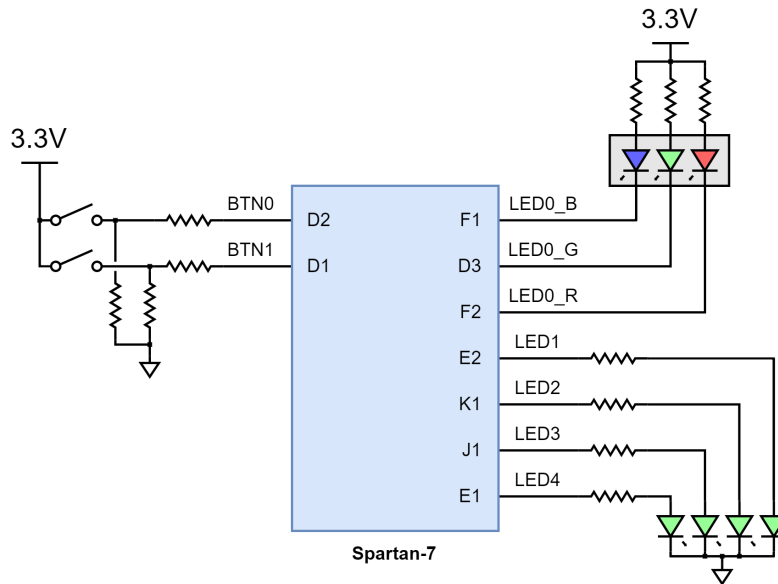

Figure 6.1 Cmod S7 Basic I/O

7 DIP Header

The Cmod S7 has a 48-pin DIP form factor connector, implemented as four 9-pin headers for connecting to breadboards and custom fixtures. The pins have 100 mil spacing, and the entire module is 0.7 inches by 3.05 inches. Headers J1 and J3 are separated by 700 mil lengthwise along the Cmod, measured from the center of the innermost pins, as are headers J2 and J4. Headers J1 and J2 are separated by 600 mil across the board, as are headers J3 and J4. Of the 48 possible pin locations, 36 are populated on the four headers. Of these, 32 are directly connected to FPGA Digital I/Os, 2 are voltage-divided and connected to FPGA analog inputs, and two are connected to power pins. The pin and header numbers are shown in Figure 7.1.

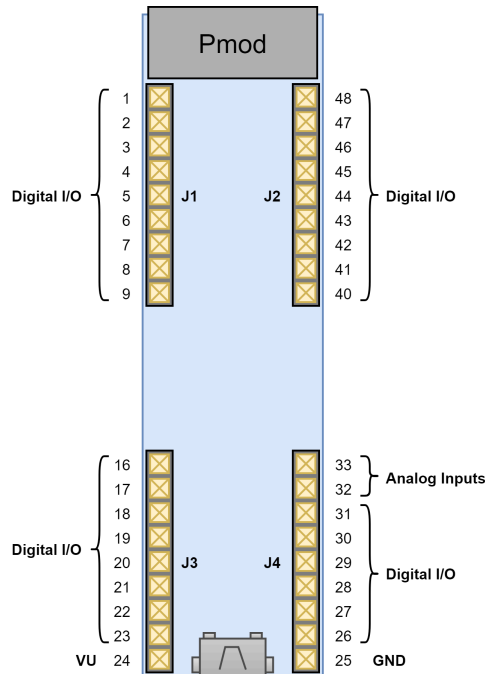

Figure 7.1 DIP Pin Diagram

VU (pin 24) can be used to power the Cmod S7 when it is not connected to a USB Host. When the device is connected to a USB host, VU is driven by the 5V rail of the USB connector and can be used to power devices external to the Cmod S7. See the Power Supplies section for more information.

7.1 DIP Digital I/O

The pins directly connected to the FPGA can be used as general purpose inputs or outputs. Each of these pins is connected to the FPGA via a 240 Ohm series resistor. The series resistors prevent short circuits that can occur if a user accidentally drives a signal that is supposed to be used as an input. The downside to this added protection is that these resistors limit the maximum switching speed of these signals to 25 MHz. These pins support input voltages of up to 3.5V.

For more information on the electrical characteristics of these pins, please see Xilinx's [Spartan-7 Datasheet \(https://docs.xilinx.com/v/u/en-US/ds189-spartan-7-data-sheet\)](https://docs.xilinx.com/v/u/en-US/ds189-spartan-7-data-sheet).

7.2 Analog Inputs

Pins 32 and 33 of the DIP headers are used as analog inputs to the XADC module of the FPGA. The FPGA expects that the inputs range from 0V-1V, so resistor-divider circuits are used on the Cmod S7 to scale down the input voltage from 3.3V. This circuit is shown in Figure 7.2.1. This circuit allows the XADC module to accurately measure any voltage between 0V and 3.3V (relative to GND on pin 25) that is applied to these pins. The analog inputs can tolerate input voltages of up to 5.5V, though any voltage above 3.3V will be read as 3.3V by the XADC module.

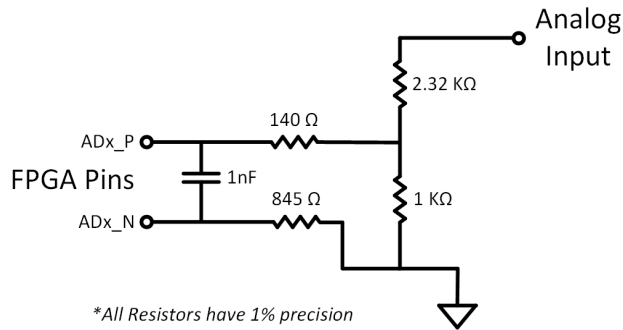

Figure 7.2.1 Analog Input Circuit

The XADC core within the Spartan-7 is a dual-channel 12-bit analog-to-digital converter capable of operating at 1 MSPS. Either channel can be driven by either of the two auxiliary analog inputs to the DIP pins. The XADC core is controlled and accessed from a user design via the Dynamic Reconfiguration port (DRP). The DRP also provides access to a temperature sensor that is internal to the FPGA. For more information on using the XADC core, refer to Xilinx UG480 (https://docs.xilinx.com/v/u/en-US/ug480_7Series_XADC), titled “7 Series FPGAs and Zynq-7000 All Programmable SoC XADC Dual 12-Bit 1 MSPS Analog-to-Digital Converter”. A demo that uses the XADC core is available on the Cmod S7 Resource Center (<https://digilent.com/reference/programmable-logic/cmod-s7/start>)

8 Pmod Connector

Pmod connectors are 2×6, right-angle, 100-mil spaced female connectors that mate with standard 2×6 pin headers. Each 12-pin Pmod connector provides two 3.3V VCC signals (pins 6 and 12), two Ground signals (pins 5 and 11), and eight logic signals, as shown in Figure 8.1. The VCC and Ground pins can deliver up to 200mA of current, but care must be taken not to exceed any of the power budgets of the onboard regulator or the external power supply (described in the Power Supplies section).

Warning: Since the Pmod pins are connected to Spartan-7 FPGA pins using a 3.3V logic standard, care should be taken not to drive these pins over 3.4V.

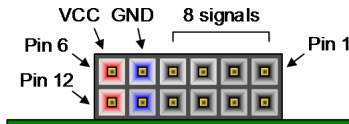

Figure 8.1 Pmod Diagram

Digilent provides a large collection of Pmod accessory boards that can attach to Pmod expansion connectors to add ready-made functions like A/D's, D/A's, motor drivers, sensors, and other functions. See www.digilentinc.com (<http://www.digilentinc.com>) for more information.

The Cmod S7 has one “standard” type Pmod connector, and the FPGA pin connections for it are described in Table 8.1. Standard Pmod connectors are connected to the FPGA via 200 Ohm series resistors. The series resistors prevent short circuits that can occur if a user accidentally drives a signal that is supposed to be used as an input. The downside to this added protection is that these resistors can limit the maximum switching speed of the data signals.

	Pmod JA
Pmod Type	Standard
Pin 1	J2
Pin 2	H2
Pin 3	H4
Pin 4	F3
Pin 7	H3
Pin 8	H1
Pin 9	G1
Pin 10	F4

Table 8.1. Cmod S7 Pmod Pinout