

# SERIES RN & RN-V

## RIBBON WIRE

# RIBBON BONDING WEDGES FOR GOLD AND ALUMINUM WIRE

**SAMPLE PART NUMBER:** M- RN-O-D-1/16-1-45-CG-.5x5-2-M- \*

**SYMBOL EXPLANATION:** 1 2 3 4 5 6 7 8 9 10 11 12

- MATERIAL:**
  - M = Ceramic
  - C = Tungsten Carbide
  - T = Titanium
  - All other: See Material Selection Guide
- SERIES:** RN
- WIRE FEED:** O = Standard Feed  
V = Vertical Feed
- FRONT/BACK RADIUS:** See Radius Option Chart  
\*For special Radius sizes insert an X Please specify FR/BR
- SHANK DIA.:** Please Specify Diameter
- TOOL LENGTH:** Please Specify Length
- HOLE ANGLE:** for RN (30°, 38°, 45°, 52°, 55°, 60,°) for RN-V (45°, 55°, 60,°)  
for RN-V with A8D Opt.(45°, 52°)

(12) See Tool Option

(11) **FOOT FINISH:**  
**M** = Matte finish (FR, BR, & Bond Flat)  
**P** = Polish finish (FR, BR, & Bond Flat)  
**MP** = Polish finish (FR, BR), and Matte finish (Bond Flat)

(10) **Bond Length:** See Standard Chart  
 Example: BL of .0020 = 2  
 Note: We do not recommend bond lengths any larger than .005".

(9) **RIBBON SIZE:** See Standard Chart  
 Example: .0005 x .005 = .5 x 5  
 Thickness x Width

(8) **FOOT TYPE:** **F** = Flat  
**CG** = Cross Groove  
**DT** = Diamond Tip  
 (Please specify Ribbon size)

For special sizes or dimensions insert an (X) in the appropriate position of the part number then specify what (X) equals. Example: M-RN-O-X-1/16-3/4-45-CG-.5x5-2-M-A7 (X) FR=.0012, BR=.0007

RADIUS OPTION CHART	OPTION LETTER		A	B	C	D	E	F	G	H	I	J	K	L	M	N
	FRONT RADIUS	in.	.0005	.0005	.0010	.0010	.0010	.0015	.0015	.0015	.0015	.0020	.0020	.0020	.0020	.0020
	BACK RADIUS	μ	13	13	25	25	25	38	38	38	38	51	51	51	51	51
	in.	0	.0005	0	.0005	.0010	0	.0005	.0010	.0015	0	.0005	.0010	.0015	.0020	
	μ	0	13	0	13	25	0	13	25	38	0	13	25	38	51	

For Vertical Feed: Tmax. for Dia. 1/16 = .0190 and for A8D: Tmax=.0243, Supplies only to Standard size Ø1/16, larger tool Ø are different.

Size Restrictions for Vertical Feed Tools		
STANDARD		
TD	Maximum Ribbon Width	Maximum "T" Dimension
1/16	.0150	.0190
3/32	.0300	.0210
A8D Option, RW up to .0070		
TD	Maximum Ribbon Width	Maximum "T" Dimension
1/16	.0070	.0243
A8D Option, RW .0080 and larger		
TD	Maximum Ribbon Width	Maximum "T" Dimension
1/16	.0120	.0190
Larger Tool Ø, Ribbon Width and "T" Dimensions available upon request		
RW = Ribbon Width		

STANDARD CHART		RN		FOR RIBBON THICKNESS: .00025" THROUGH .0020"											
				WIDTHS: .002" THROUGH .030"											
RIBBON WIDTH	RIBBON THICKNESS	BL		T(30°38°)		T(45° 52°)		T(55° 60°)		W					
in.	μ	in.	μ	in.	μ	in.	μ	in.	μ	in.	μ	in.	μ		
<b>Tolerance</b>		±.0002 ±.05		±.0005 ±.13		±.0005 ±.13		±.0005 ±.13		±.0002 ±.5					
.0020	51	.00025 through .00125	6.4	.0010	25	.0140	356	.0110	279	.0090	229	.0055	140		
				.0015	38	.0140	356	.0110	279	.0090	229				
				.0020	51	.0150	381	.0120	305	.0090	229				
				.0025	64	.0150	381	.0120	305	.0100	254				
.0030	76	.00025 through .00125	6.4	.0030	76	.0160	406	.0130	330	.0100	254	.0065	165		
				.0010	25	.0150	381	.0130	330	.0100	254				
				.0015	38	.0150	381	.0140	356	.0100	254				
				.0020	51	.0160	406	.0140	356	.0110	279				
.0040	102	.00025 through .00125	6.4	.0025	64	.0160	406	.0140	356	.0110	279	.0075	191		
				.0030	76	.0160	406	.0150	381	.0120	305				
				.0005	13	.0020	51	.0160	406	.0140	356			.0110	279
				.0025	64	.0160	406	.0140	356	.0110	279				
.0050	127	.0005 through .0020	13	.0030	76	.0160	406	.0150	381	.0120	305	.0085	216		
				.0035	89	.0170	432	.0150	381	.0120	305				
				.0025	64	.0160	406	.0140	356	.0110	279				
				.0020	51	.0160	406	.0150	381	.0120	305				
.0070	178	.0005 through .0020	13	.0040	102	.0170	432	.0160	406	.0130	330	.0125	318		
				.0025	64	.0160	406	.0140	356	.0110	279				
				.0030	76	.0160	406	.0150	381	.0120	305				
				.0035	89	.0170	432	.0150	381	.0120	305				
.0100	254	.0005 through .0020	13	.0040	102	.0170	432	.0160	406	.0130	330	.0155	394		
				.0025	64	.0160	406	.0140	356	.0110	279				
				.0030	76	.0160	406	.0150	381	.0120	305				
				.0035	89	.0170	432	.0150	381	.0120	305				
.0120	305	.0005 through .0020	13	.0040	102	.0170	432	.0160	406	.0130	330	.0175	445		
				.0025	64	.0160	406	.0140	356	.0110	279				
				.0030	76	.0160	406	.0150	381	.0120	305				
				.0035	89	.0170	432	.0150	381	.0120	305				
.0150	381	.0005 through .0020	13	.0025	64	.0160	406	.0140	356	.0110	279	.0205	521		
				.0030	76	.0160	406	.0150	381	.0120	305				
				.0035	89	.0170	432	.0150	381	.0120	305				
				.0040	102	.0170	432	.0160	406	.0130	330				
.0200	508	.0005 through .0020	13	.0025	64	.0160	406	.0140	356	.0110	279	.0255	648		
				.0030	76	.0160	406	.0150	381	.0120	305				
				.0035	89	.0170	432	.0150	381	.0120	305				
				.0040	102	.0170	432	.0160	406	.0130	330				

\*Other sizes available upon request \*All dimensions and tolerances are for reference only  
 "T" To be determined according to the size of FR and BR and Hole Bore Length

# SERIES RN & RN-V

## RIBBON WIRE

FOR AUTOMATIC BONDERS

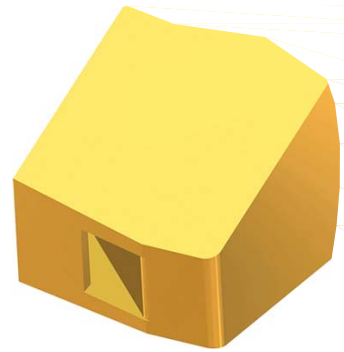
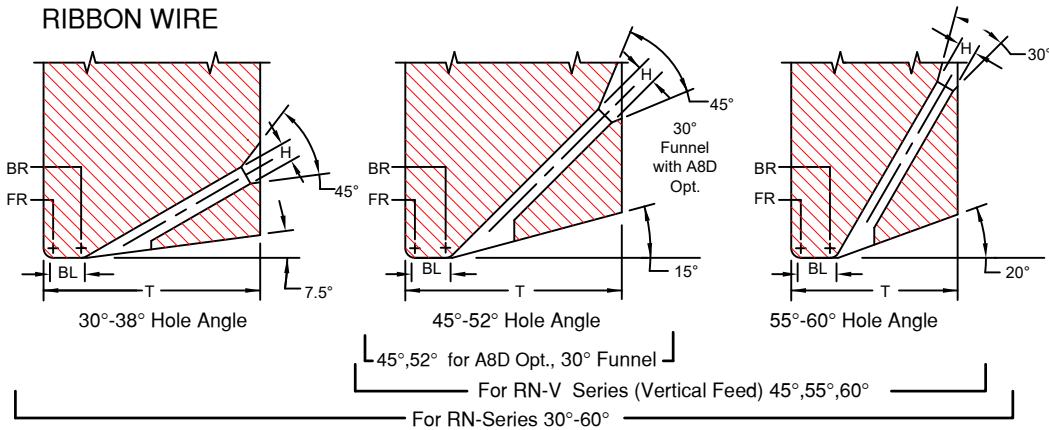

Available Vertical Hole Ø marked with X

	TD		TDF		For Vertical Hole
	in.	mm	in.	mm	
1/16	.0624	1.59	.0460	1.17	
1/16	.0624	1.59	.0590	1.50	X
	.0784	1.99	.0630	1.60	
	.0784	1.99	.0720	1.83	X
3/32	.0937	2.38	.0880	2.24	X
	.1180	3.00	.0985	2.50	
1/8	.1249	3.17	.0937	2.38	
1/8	.1249	3.17	.1180	3.00	

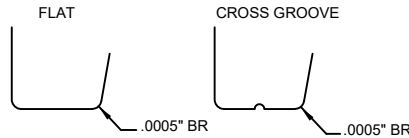

We recommend a .0005" back radius and a cross groove or a flat bond foot when ordering tools for gold wire thermosonic bonding. For more gold wire application information see **Tech Tip**

### RN-SERIES

Ribbon Width: .0020" through .030"  
Ribbon Thickness: .00025" through .0020"

For large Ø

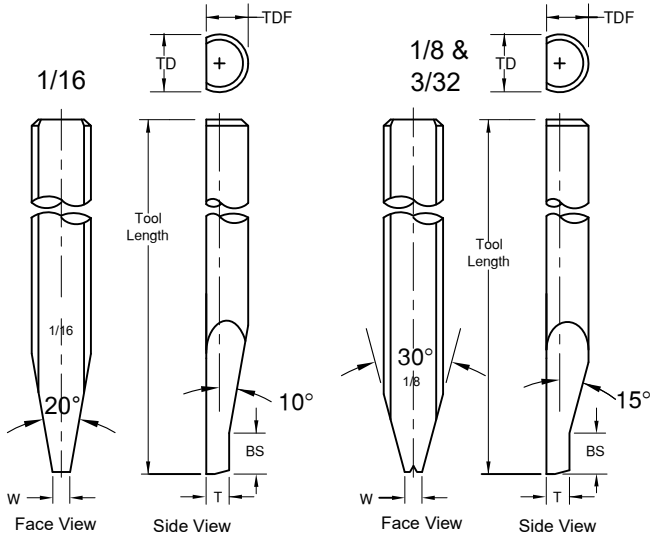

### RN-V SERIES

#### VERTICAL FEED DEEP ACCESS

Ribbon Width: .0020" through .030", Ribbon Thickness: .00025" through .0020"

NOTE: We recommend our A8D option for enhanced wire control. Our standard vertical feed has slightly more clearance but less wire control. See Tool Option for illustration. To order just add A8D in space 12. Not suitable for F&K and Hesse Mechatronics machine

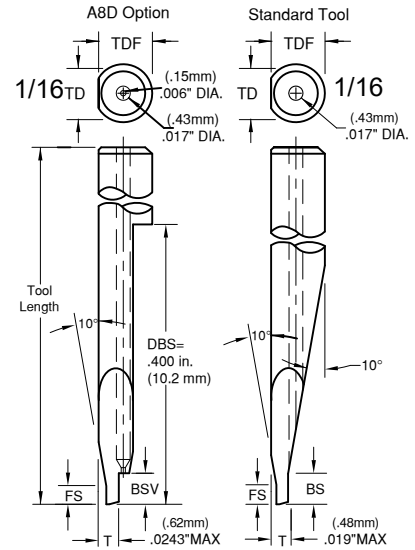

#### A8D Option

Hole Angle	BSV	
	in.	mm
45°	.035	.89
52°	.050	1.27

Standard: Ø 1/16, 45° to 52° Hole Angle : BS"=.045" (1.14mm) .  
Supplies only to Standard size Ø 1/16, **larger tool Ø are different.**  
Standard: (BS) supplied unless otherwise specified. See Tool Options #A3

Standard: Ø 1/16 45° to 52° Hole Angle :  
**FS=.015"**(.38mm) **BS"=.045"** (1.14mm)  
Standard: (FS&BS) supplied unless otherwise specified. See Tool Options  
**No FS if T=MAX**

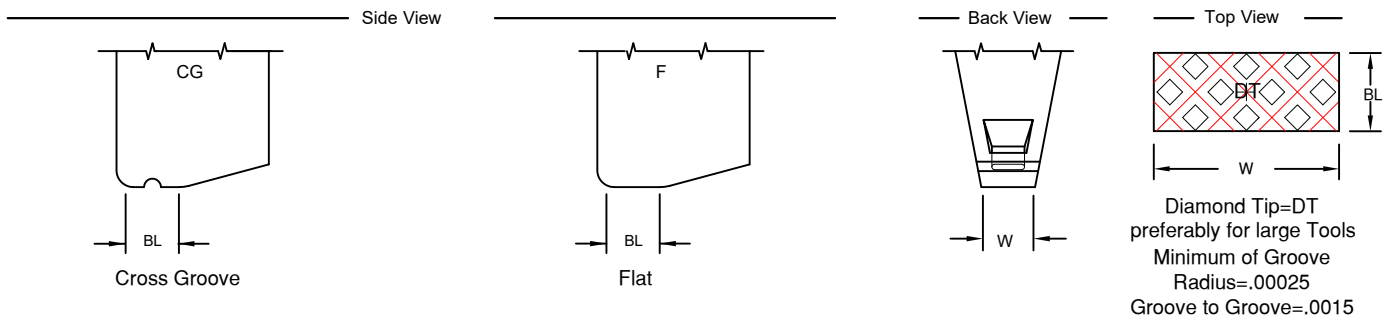

# OPTIONS



Below are shown various problem situations that can occur during bonding operations and their solutions. When choosing an option, please note the corresponding option number (A1, A2, etc.) when completing the part number from the Ordering Information sections. **These option numbers should appear as the last item in the part number.**

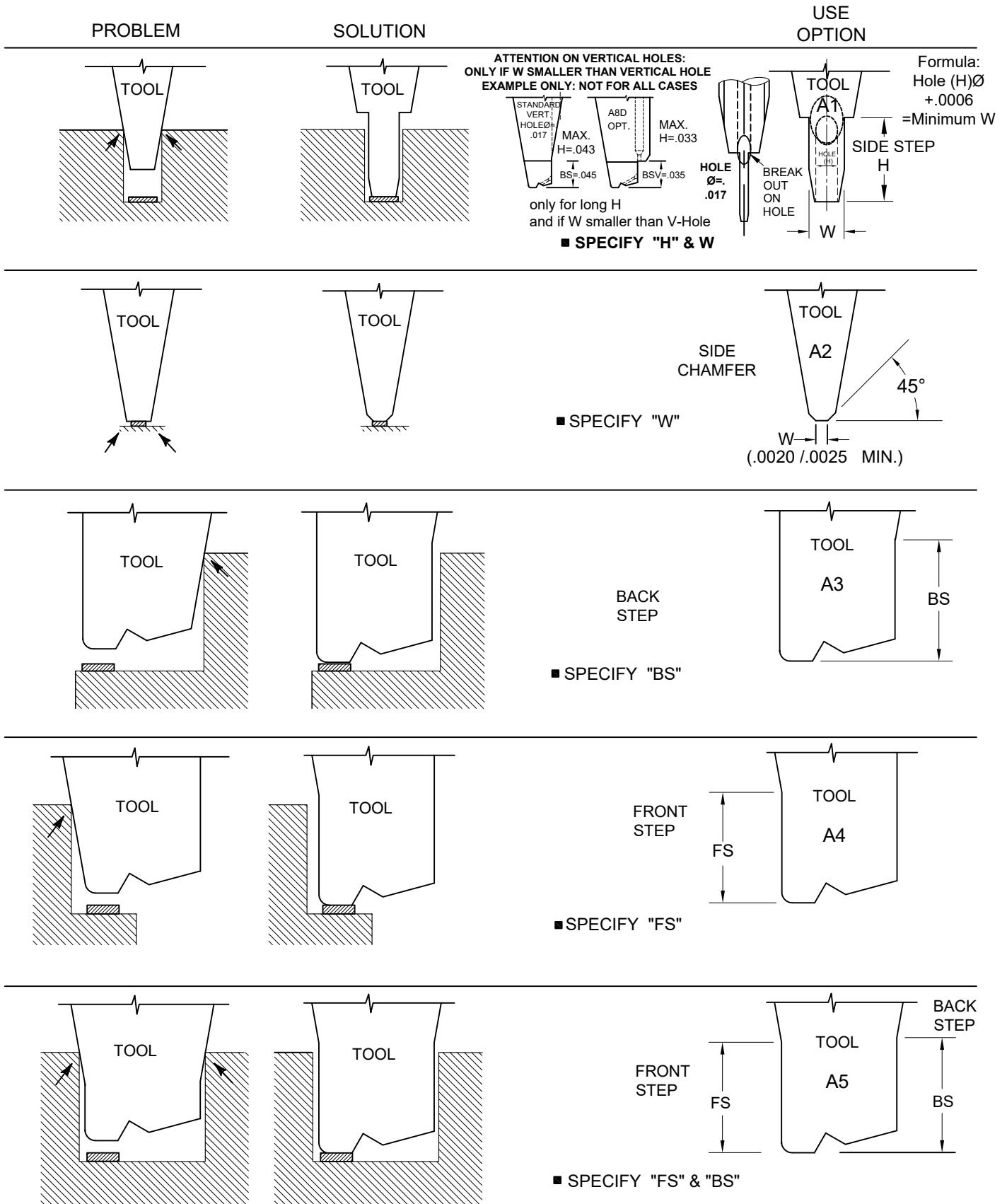

# OPTIONS



Below are shown various problem situations that can occur during bonding operations and their solutions. When choosing an option, please note the corresponding option number (A1, A2, etc.) when completing the part number from the Ordering Information sections. **These option numbers should appear as the last item in the part number.**

PROBLEM	SOLUTION	USE OPTION
		<p>For CS, CN, CL use <b>C-SERIES</b></p> <p>■ SPECIFY "C" Use A6 for Series with Front Angle</p> <p><b>A6</b> or choose <b>C-SERIES</b></p>
		<p>■ SPECIFY "T"</p> <p><b>A7</b></p>
	<p>BACK STEP VERTICAL</p>	<p><b>A8D</b></p> <p>DBS=400 STANDARD</p> <p>BSV=.035</p>
<p>IF OTHER THAN STANDARD, SPECIFY "BSV" &amp; "DBS" MINIMUM "BSV" IS .035 in. (.89mm) FOR 45° HOLE AND BSV= .050 in. (1.27mm) FOR 52° HOLE.</p>		<p><b>A8D OPTION, NOT SUITABLE FOR F &amp; K DELVOTEC AND HESSE MECHATRONICS MACHINES</b></p>
		<p>BACK CHAMFER</p> <p>■ SPECIFY "C" AND ANGLE IF OTHER THAN STANDARD 45°</p> <p><b>A9</b></p> <p>45°</p> <p>C</p>